

# MERIDIAN<sup>®</sup>

**HD8 • HD10 • TL10 • TL12**  
TRUCKLOAD AUGER



[meridianmfg.com/truck-load-conventional-auger](http://meridianmfg.com/truck-load-conventional-auger)

## OPERATOR'S MANUAL



# PRODUCT REGISTRATION FORM



**Attention Dealers:**

You can register products online through the Dealer Login: <http://dealers.meridianmfg.com/login/>

It is mandatory to register your product in order to qualify for future warranties that may arise. Knowingly falsifying information on this form will result in the voiding of the product warranty.

You may scan/photograph this completed form (must be legible), email it to: [register@meridianmfg.com](mailto:register@meridianmfg.com)  
A copy of this form may also be mailed to Meridian Manufacturing Inc.

Buyer's Name _____	Dealer's Name _____
Address _____	Address _____
City, Prov/State _____	City, Prov/State _____
Postal Code/Zip Code _____	Postal Code/Zip Code _____
Phone Number _____	Phone Number _____

**Note:** Registering a product in multiple entry format is only allowed when the product has the same model number and the same dealer, however each serial number must be legibly listed for each unit. Delivery dates for a multiple entry must be within a one month time frame.

Product Information: \_\_\_\_\_

Model Number _____	Serial Number _____
Invoice Date _____	

**Important:** Please send this form to the Meridian Manufacturing Inc. location which built this product being registered. If you require further assistance call you're dealer or the Meridian outlet nearest to your location.

We want to thank you for purchasing a Meridian manufactured product. Whether this is your first Meridian purchase or you have been a customer for years, you are now part of the Meridian community of customers and we appreciate your business.

It is important that you now complete the product registration information and this form indicating you have received delivery. This registration and information is necessary to ensure you have access to warranty and product updates in the event it be required in the future.

Registration can be completed by using this form or visiting your dealer who will complete the form online. You will be given access to the Meridian community and become eligible for updates, special offers and prizes.

Again thank you for choosing Meridian.

I have thoroughly instructed the buyer on the above described equipment. The review included the content of this manual, equipment care, adjustments, safe operation and warranty policy.

Date \_\_\_\_\_ Dealer's Signature \_\_\_\_\_

The above equipment and this manual have been received by me. I have been thoroughly instructed as to care, adjustments, safe operation and applicable warranty policy.

Date \_\_\_\_\_ Buyer's Signature \_\_\_\_\_

This page intentionally left blank

## TABLE OF CONTENTS

<b>DESCRIPTION</b>	<b>PAGE</b>
Section 1: INTRODUCTION . . . . .	1-1
Section 2: SAFETY . . . . .	2-1
2.1 Safety Orientation . . . . .	2-2
2.2 General Safety . . . . .	2-2
2.3 Equipment Safety Orientation . . . . .	2-3
2.4 Safety Decals . . . . .	2-3
2.4.1 Applying Decals . . . . .	2-3
2.5 Decal Location . . . . .	2-4
2.6 Work Preparation . . . . .	2-5
2.7 Placement Safety . . . . .	2-5
2.8 Lock-Out Tag-Out Safety . . . . .	2-5
2.9 Engine Safety . . . . .	2-6
2.10 Electrical Safety . . . . .	2-7
2.11 PTO Safety . . . . .	2-7
2.12 Tire Safety . . . . .	2-7
2.13 Operating Safety . . . . .	2-8
2.14 Maintenance Safety . . . . .	2-8
2.15 Safety Guard Description . . . . .	2-9
2.16 Workplace Hazard Area . . . . .	2-10
2.17 Transport Safety . . . . .	2-11
2.18 Storage Safety . . . . .	2-11
Section 3: OPERATION . . . . .	3-1
3.1 Machine Components . . . . .	3-2
3.2 Components and Controls . . . . .	3-3
3.3 Frame Mount Auger Mover . . . . .	3-5
3.3.1 Lift Cylinder Relief Valve . . . . .	3-6
3.3.2 Wheel Speed Needle Valve . . . . .	3-6
3.3.3 Three Spool Control Valve . . . . .	3-7
3.4 Transportation . . . . .	3-8
3.5 New Machine Break-In . . . . .	3-9
3.6 Pre-Operation Checklist . . . . .	3-9
3.7 Auger Placement . . . . .	3-10

continued on next page

## TABLE OF CONTENTS

<b>DESCRIPTION</b>	<b>PAGE</b>
3.8 Operating on Site . . . . .	3-11
3.8.1 Auger Drive Systems and Lock-Out . . . . .	3-11
3.8.2 Emergency Shut-Down . . . . .	3-12
3.8.3 Normal Shut-Down . . . . .	3-12
3.8.4 Everyday Operation . . . . .	3-12
3.9 Storage . . . . .	3-13
Section 4: SERVICE AND MAINTENANCE . . . . .	4-1
4.1 Fluids And Lubricants . . . . .	4-1
4.1.1 Greasing . . . . .	4-2
4.2 Servicing Intervals . . . . .	4-3
4.2.1 Every 10 Hours or Daily . . . . .	4-3
4.2.2 Every 50 Hours or Weekly . . . . .	4-3
4.2.3 Every 200 Hours or Annually . . . . .	4-4
4.3 Maintenance Procedures . . . . .	4-5
4.3.1 Drive Shaft Pillow Block Replacement . . . . .	4-5
4.3.2 Drive and Pump Belt Replacement . . . . .	4-6
4.3.3 Winch Cable Replacement . . . . .	4-8
4.3.4 Head-End Drive Chain and Sprockets . . . . .	4-10
4.3.5 Mover Drive Assembly Gear Adjustment . . . . .	4-10
4.3.6 Repack Wheel Bearings . . . . .	4-11
4.3.7 Truss Cable Adjustment . . . . .	4-12
4.3.8 Reversing Gearbox Linkage Adjustment . . . . .	4-13
4.3.9 Mover Pump Hydraulic Schematic . . . . .	4-14
4.3.10 Change Hydraulic Oil . . . . .	4-15
4.3.11 Change Hydraulic Oil Filter . . . . .	4-15
Section 5: TROUBLESHOOTING . . . . .	5-1
Section 6: REFERENCE . . . . .	6-1
Warranty Statement	

## Section 1: INTRODUCTION

Thank you for choosing a Meridian® Truck Load Auger.

### DECLARATION OF CONFORMITY

We the Manufacturer:  
Meridian Manufacturing Inc.  
2800 Pasqua Street North  
Sherwood SK, Canada S4K 0A8

Declare that the Augers listed herewithin conform to the 2006/42/EC Machinery Directive.

The equipment we design and manufacture meet the exacting standards of the agricultural industry. This Auger and Tube Assembly is designed for the movement of grains and cereals.

Keep this manual for future reference. Call your dealer, distributor or our office if you need assistance, information, additional/replacement copies, or a digital copy of this document.

Information provided herein is of a descriptive nature. Meridian Manufacturing Inc. reserves the right to modify the machinery design and specifications without any preliminary notice.

Performance quality may depend on the product being handled, weather conditions and other factors.

### SERIAL NUMBER LOCATION

Always give your dealer the serial number when ordering parts, requesting service or asking for other information. The serial number is located on the tube.

- Use the space provided for easy reference:

Auger Model No: \_\_\_\_\_

Auger Serial No: \_\_\_\_\_

Aux. Equip. Model No: \_\_\_\_\_

Aux Equip. Serial No: \_\_\_\_\_



Fig 1 - Serial number location

This page intentionally left blank

## Section 2: SAFETY

3 Big Reasons why safety is important to you:

- Accidents Disable and Kill
- Accidents Cost
- Accidents Can Be Avoided

The Safety Alert Symbol means:



ATTENTION!  
BECOME ALERT!  
YOUR SAFETY IS INVOLVED!

The Safety Alert Symbol identifies important safety messages on the auger and in this manual.

The following signal words are used in this manual to express the degree of hazard for areas of personal safety.

When you see the symbol and/or the signal words described below, obey the accompanying message to avoid possible injury or death.



Indicates a hazardous situation that, if not avoided, will result in death or serious injury. This signal word is limited to the most extreme situations. Typically for machine components which, for functional purposes, cannot be guarded.



Indicates a hazardous situation, if not avoided, could result in death or serious injury. This word identifies hazards that are exposed when guards are removed. It may be used to alert against unsafe practices.



Indicates a hazardous situation, if not avoided, could result in minor or moderate injury. It may be used to alert against unsafe practices.



Indicates practices or situations which may result in the malfunction of, or damage to equipment.



Safety instructions (or equivalent) signs indicate specific safety-related instructions or procedures.

## 2.1 SAFETY ORIENTATION

YOU are responsible for the SAFE operation and maintenance of your Meridian® auger. Be sure that everyone who will operate, maintain or work around it, is familiar with the safety, operating and maintenance procedures.











This manual will take you step-by-step through your working day. It will alert you to all the safe practices that should be adhered to while operating the auger.

Remember, you are the key to safety. Good safety practices not only protect you but also the people around you. Make these practices a regular part of your safety program. Be certain that everyone who will work with this equipment follows these procedures.

Most accidents can be prevented. Do not risk injury or death by ignoring good safety practices.

- Auger owners must give operating instructions to employees before allowing them to operate the machine.
  - Procedures must be reviewed annually thereafter, as per OSHA (Occupational Safety and Health Administration) regulation 1928.57.
  - The operator must be responsible, properly trained and physically able. They should be familiar with farm machinery in general.
- Think SAFETY! Work SAFELY!

## 2.2 GENERAL SAFETY

- Read and understand the Operator's Manual and all safety decals before operating, maintaining, adjusting or unplugging the auger. 
- Only trained, competent persons shall operate the auger. An untrained person is not qualified to operate the machine.
- Have a first-aid kit available for use should the need arise. 
- Provide a fire extinguisher for use in case of an accident. Store in a highly visible place. 
- Do not allow riders.
- Do not allow children, spectators or bystanders within hazard area around the machine.
- Wear personal protective equipment (PPE). This list may include but is not limited to:
  - Hard hat 
  - Protective shoes with slip resistant soles 
  - Eye protection 
  - Work gloves 
  - Hearing protection 
  - Respirator or filter mask 
  - Hi-Visibility safety vest 
- Never use alcoholic beverages or drugs which can hinder alertness or coordination while operating this equipment.
  - Consult your doctor about operating this machine while taking prescription medications.
- If the elderly are assisting with farm work, their physical limitations need to be recognized and accommodated.
- Review safety related items annually with all personnel who will be operating or maintaining the auger.

## 2.4 EQUIPMENT SAFETY GUIDELINES

Safety of the operator and bystanders is one of the main concerns when designing and developing this auger. However, every year many accidents occur which could have been avoided by a few seconds of thought, and a more careful approach to handling equipment.

- In order to provide a better view, certain images in this manual may show an assembly with safety guards removed.
  - Equipment should never be operated in this condition
  - All guards must be in place.
  - If removal becomes necessary for repairs, replace guard prior to use.

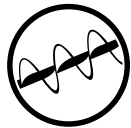

- This equipment is dangerous to children and persons unfamiliar with its operation.
- Never exceed the limits of a piece of machinery. If its ability to do a job, or to do so safely, is in question - DO NOT TRY IT.
- Do not modify the equipment in any way. Unauthorized modification result in serious injury or death and may impair the function and life of the equipment.
- The design and configuration of this auger includes safety decals and equipment. They need to be clean, readable and in good condition.

## 2.3 SAFETY DECALS

- Keep safety decals clean and legible at all times.
- Replace safety decals that are missing or have become illegible.
- Replaced parts must display the same decal(s) as the original parts.
- All safety decals have a part number in the lower right hand corner. Use this part number when ordering replacements.
- Decals are available from your authorized distributor, dealer's parts department, or from Meridian Manufacturing Inc.

### 2.3.1 Applying Decals:

1. Be sure the application area is clean and dry. Ensure the surrounding temperature is above 10°C (50°F).
  - a. Remove all dirt, grease, wax from surface.
  - b. Clean the area with a non-ammonia based cleaner.
  - c. Wipe the clean surface with isopropyl alcohol on paper towel, and allow to dry.
2. Determine the exact position before you remove the backing paper.
3. Peel a small portion of the split backing paper.
4. Align the decal over the specified area. Use a squeegee to carefully press the small portion, with the exposed adhesive backing, into place.
5. Slowly peel back the remaining paper and carefully smooth the rest of the decal into place.
6. Small air pockets can be pierced with a pin and smoothed out using the squeegee, or a piece of sign backing paper.

## 2.5 DECAL LOCATION

The following illustration shows the general location of decals on this auger. The position of decals may vary depending on the machine's options. Decals are not shown at actual size.

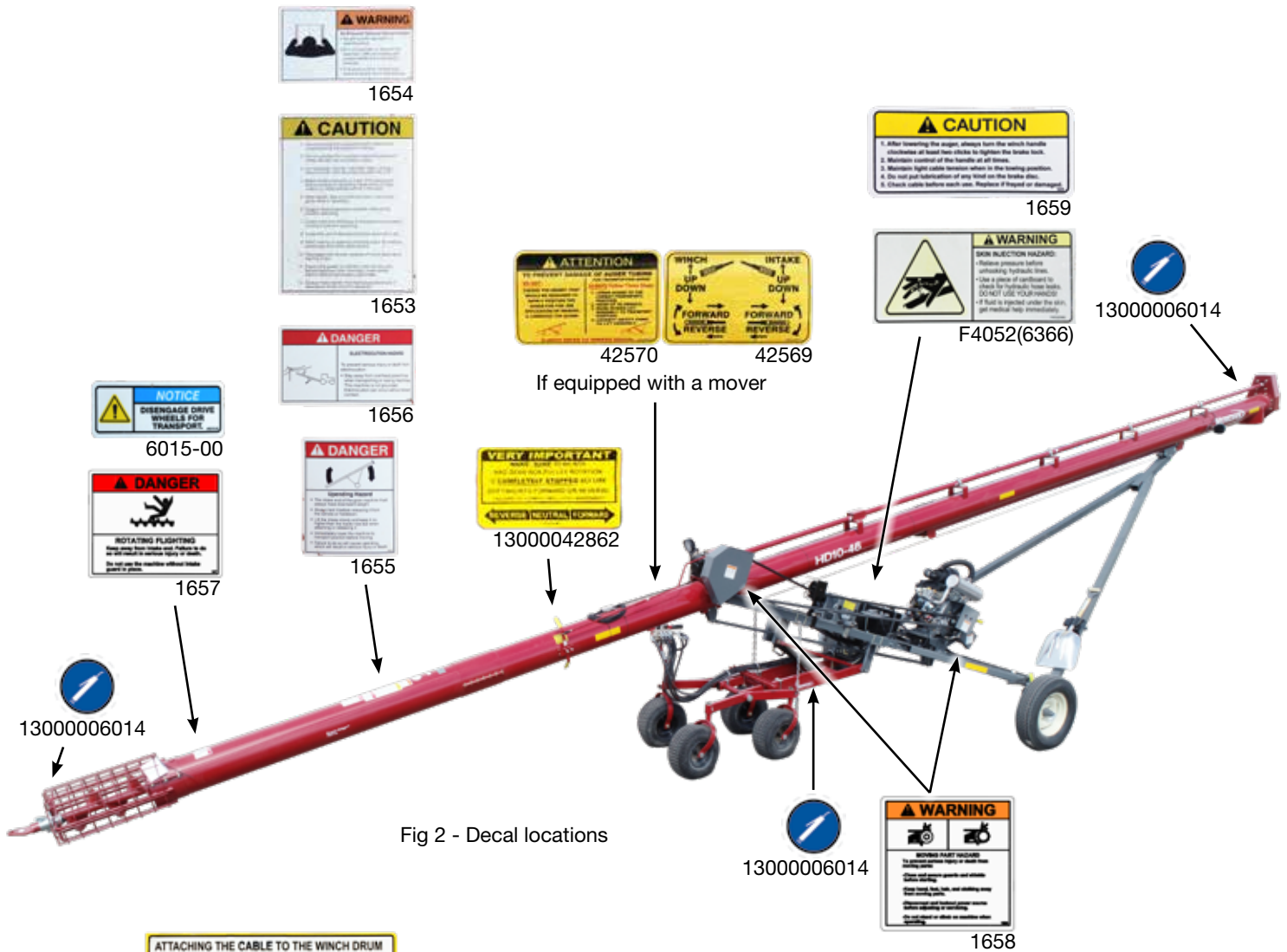

Fig 2 - Decal locations

- Red reflectors: on end of discharge spout, and discharge-side of axle.
- Amber reflectors: on the sides of discharge, fork-side of axle, on undercarriage, and at less than 15 ft intervals along the tube.

**REMEMBER** - If safety decals have been damaged, removed, become illegible, or parts were replaced without signage, new ones must be applied. New decals are available from your authorized dealer.

## 2.6 WORK PREPARATION

- Never operate the auger and its engine until you have read this manual, and understand the information.
- Be familiar with the safety messages found on the decals around this unit.
- Personal protective equipment (PPE) include:
  - Hard hat
  - Eye protection
  - Protective shoes
  - Work gloves



They are recommended during installation, placement, operation, maintenance and removal of the equipment.

- Do not allow long hair, loose fitting clothing or jewelry to be around equipment.
- **PROLONGED EXPOSURE TO LOUD NOISE MAY CAUSE PERMANENT HEARING LOSS!**

Agricultural equipment can often be noisy enough to cause permanent, partial hearing loss. We recommend that you wear hearing protection on a full-time basis if the noise in the Operator's position exceeds 80 db.



Noise over 85 db on a long-term basis can cause severe hearing loss.

Noise over 90 db adjacent to the operator over a long-term basis may cause permanent, total hearing loss.

### Note:

Hearing loss from loud noise (tractors, chain saws, radios, etc.) is cumulative over a lifetime without hope of natural recovery.

- Clear working area of stones, branches or hidden obstacles that might be hooked or snagged, causing injury or damage.
- Operate only in daylight or good artificial light.
- Be sure machine is in a stable position, is adjusted and in good operating condition.
- Ensure that all safety guards and safety decals are properly installed and in good condition.
- Before starting, inspect the unit for any loose bolts, worn parts, cracks, leaks or frayed belts. Make the necessary repairs.
  - Always follow the maintenance instructions.



## 2.7 PLACEMENT SAFETY

- Stay away from overhead power lines when operating or moving the auger. Electrocutation can occur without direct contact.
- Keep auger as low as possible.
- Chock auger wheels before operating.
- Position auger providing enough space for trucks to load or unload.
- Operate auger on level ground, free of debris.

## 2.8 LOCK-OUT TAG-OUT SAFETY

- Establish a formal Lock-Out Tag-Out program for your operation.
- Train all operators and service personnel before allowing them to work around the area.
- Provide tags on the machine and a sign-up sheet to record tag-out details.

## 2.9 ENGINE SAFETY

- Read and understand the operating manual provided with the engine. 
- Use proper tools to service engine.
- Do not run engine in an enclosed area. Exhaust gases contain carbon monoxide, an odorless and deadly poison.
- Store fuel in approved safety containers.
- Do not store fuel near open flame.
  - Appliances such as a stove, furnace, or water heater use a pilot light which can create sparks.
- No smoking when filling fuel tank. 
- Do not remove fuel cap while engine is running.
- Do not refuel indoors where area is not well ventilated. Outdoor refueling is preferred.
- Do not refuel while engine is running. Allow engine to cool for 5 mins before proceeding.
- Use fresh fuel. Stale fuel can gum carburetor and cause leakage.
- Check fuel lines and fittings frequently for cracks or leaks. Replace if necessary.
- Do not operate engine if fuel has spilled. Move machine away. Avoid creating any ignition until the fuel has evaporated.
- Do not run engine above rated speeds. This may result in damage and injury.
- Do not tamper with the engine speed selected by the original equipment manufacturer.
- Do not operate engine with grass, leaves, dirt or other combustible materials in muffler area.
- Do not operate engine without muffler.

- Do not tamper with governor springs, governor links or other parts which may increase the governed engine speed.
- Do not strike flywheel with hard object or metal tool. This may cause it to shatter in operation.
- Keep cylinder fins/governor parts free of grass and other debris which can affect engine speed.

### **WARNING**

#### HOT EQUIPMENT HAZARD

Do not touch muffler, cylinder or fins while engine is running. Contact will cause burns.

- Do not use this engine on any forest covered, brush covered, or grass covered unimproved land, unless a spark arrester is installed on muffler. The arrester must be maintained in effective working order by operator.

In the State of California the above is required by law (Section 4442 of the California Public Resources Code). Other states may have similar laws. Federal laws apply on federal land.

- Inspect the muffler periodically. Replace it when necessary.
  - If engine is equipped with a muffler deflector, inspect periodically. Replace with correct part.
- Do not check for spark, or crank engine with spark plug or spark plug wire removed.
- Do not run engine with air filter or its cover removed.

### **NOTICE**

#### POSSIBLE ENGINE DAMAGE

Decelerate engine slowly to stop. Avoid choking carburetor to stop engine. Choke only for an emergency stop.

## 2.10 ELECTRICAL SAFETY

- Have only a qualified electrician supply power. All wiring should comply with the ANSI/NFPA 70 electrical requirements.
- Make certain that the conveyor motor is properly grounded at the power source.
- Ensure that all electrical switches are in the OFF position before plugging the conveyor in.
- Turn machine OFF, shut down and lock out power supply (safety lock-out devices are available through your Convey-All dealer parts department) and wait for all moving parts to stop before assembling, servicing, adjusting, maintaining or repairing.
- Disconnect power before resetting any motor.
- Replace any damaged electrical plugs, cords, switches and components immediately.
- Do not work on the conveyor's electrical system unless the power cord is unplugged or the power supply is locked out.

## 2.11 PTO SAFETY

- Never use a PTO driveline without a rotating shield in good working order.
- Ensure PTO shields turn freely on the driveline.
- PTO driveline must be securely attached at both ends before operating.
- Keep body, hair, and clothing away from rotating PTO driveline.
- Keep U-joint angles small and equal.
  - Do not exceed recommended operating length for PTO driveline.
- Before starting tractor, turn power to PTO to the off position (where applicable).



## 2.12 TIRE SAFETY

- Failure to follow procedure when mounting a tire on a wheel or rim can produce an explosion and may result in serious injury or death. 
- Do not attempt to mount a tire unless you have the proper equipment and experience to do the job.
- Have a qualified tire dealer or repair service perform required tire maintenance.
- When replacing worn tires, make sure they meet the original tire specifications.
  - Never undersize.

## 2.13 HYDRAULIC SAFETY

- Always place hydraulic controls in neutral. Then relieve pressure in hydraulic system before maintaining or working on machine.
- Be sure that all components in the hydraulic system are kept in good condition and are clean.
- Replace any worn, cut, abraded, flattened or crimped hoses.
- Do not attempt any makeshift repairs to the hydraulic fittings or hoses by using tape, clamps or cements. The hydraulic system operates under extremely high-pressure.
  - Such repairs will fail suddenly and create a hazardous and unsafe condition.
- Wear proper hand and eye protection when searching for a high-pressure hydraulic leak.
  - Use wood or cardboard as a backstop instead of a hand to isolate/identify a leak.
- If injured by a concentrated high-pressure stream of hydraulic fluid, seek medical attention immediately. Serious infection or toxic reaction can develop from hydraulic fluid piercing the skin surface.

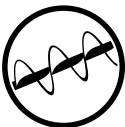
## 2.14 OPERATING SAFETY

- Anyone who will be operating this auger, or working around it, must read this manual. They must know operating, maintenance, safety info.
  - Review the manual annually.
- Clean or replace all safety decals if they cannot be clearly read and understood.
- Place all controls in neutral, and stop the engine. Remove the ignition key. Wait for all moving parts to stop before adjusting, repairing or unplugging.
- Keep all bystanders, especially children, away from the machine when running.
  - Also, when authorized personnel are carrying out maintenance work.
- Establish a Lock-Out, Tag-Out policy for the work site. Be sure all personnel are trained in and follow all procedures.
  - Lock-out, tag-out all power sources before servicing the unit or working around equipment.
- Be familiar with machine hazard area. If anyone enters the area, shut down machine immediately. Clear the area before restarting.
- Keep hands, feet, hair and clothing away from all moving/rotating parts.
 
- Do not allow riders on the auger when moving or transporting it.
- Keep working area clean and free of debris to prevent slipping/tripping.
 
- Stay away from overhead obstructions and power lines during operation and transporting. Electrocutation can occur without direct contact.
- Do not operate the auger when any guards are removed.
- Chock wheels of auger before starting.

- Be sure that auger tube is empty before raising or lowering.
- High winds may overturn auger. To avoid damage to structures and equipment, do not raise auger fully in windy conditions.
  - Do not leave auger raised, when not in use.

## 2.15 MAINTENANCE SAFETY

- Good maintenance is your responsibility. Poor maintenance is an invitation to trouble.
- Follow good shop practices.
  - Keep service area clean and dry.
  - Be sure electrical outlets and tools are properly grounded.
  - Use adequate light for job at hand.
- Review safety related items annually with all personnel who will be operating, using or maintaining the equipment.
- Use personal protection devices such as eye, hand, breathing and hearing protection, when performing any services or maintenance work.
- A fire extinguisher and first aid kit should be kept readily accessible while performing maintenance on this equipment.
 
- Periodically tighten all bolts, nuts and screws to ensure the unit is in safe condition.
- Disable the motor/engine before any service and maintenance, so the equipment can not be accidentally turned on.
- Establish a Lock-Out/Tag-Out procedure.
- When completing a maintenance or service function, make sure all safety shields and devices are installed before placing unit in service.

## 2.16 SAFETY GUARD DESCRIPTION



Fig 3 - Head-end cover



Fig 4 - Fork guard



Fig 5 - Gearbox pulley guard



Fig 6 - Gear box shaft guard



Fig 7 - Engine pulley guard



Fig 8 - PTO attachment guard

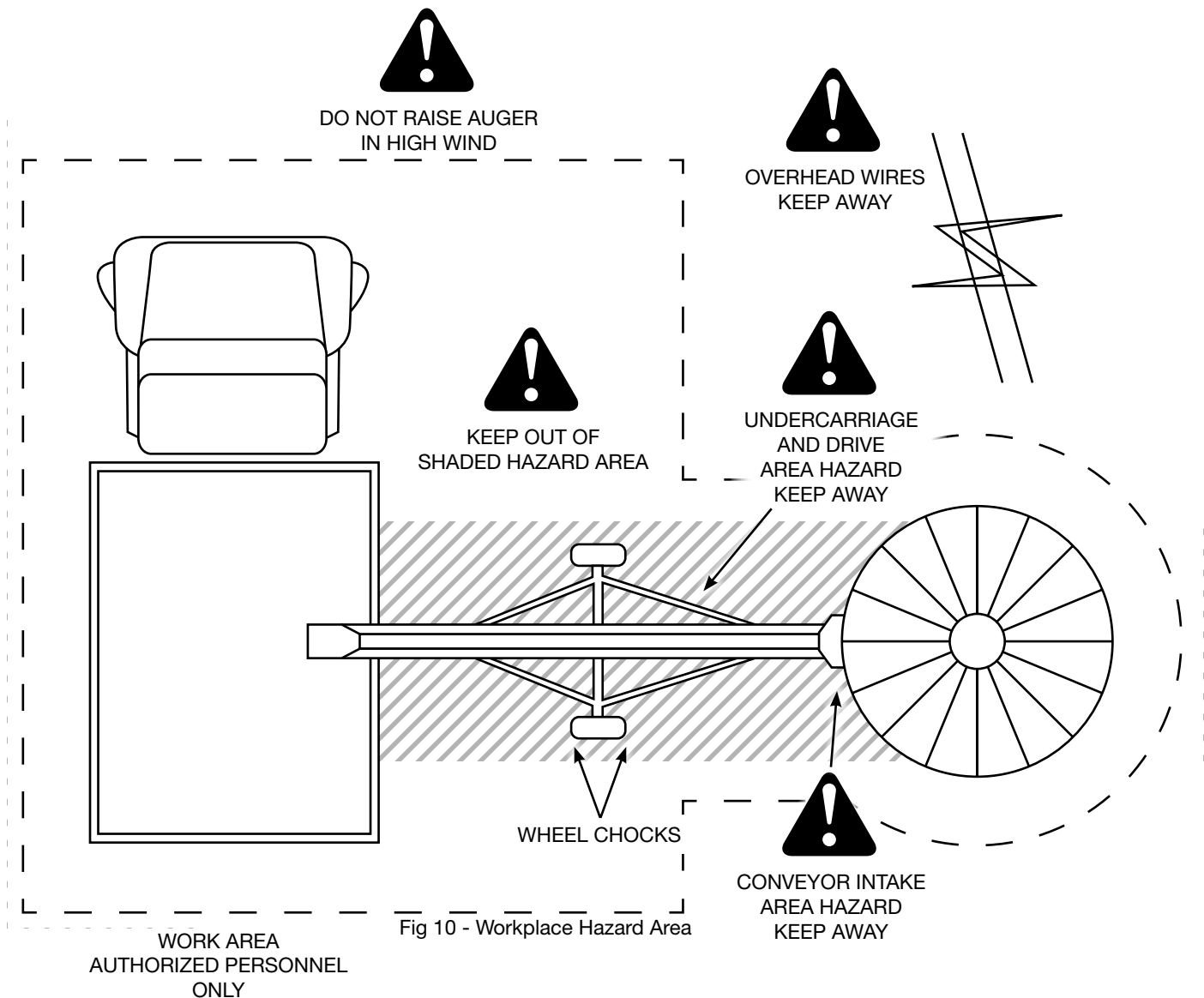

Fig 9 - Tubular drive shaft guard

## 2.17 WORKPLACE HAZARD AREA

The following illustration shows the designated work areas. This area shall be marked off with coloured nylon or plastic rope hung by portable barriers to define the designated work areas.

- Under no circumstances should children and/or other persons not involved in the operation of the equipment be allowed to trespass into the work area.
- Trespass into the area by anyone not involved in the actual operation, or trespass into a hazard area by anyone shall result in a immediate shutdown by the operator.
- It is the responsibility of the operators to see that the work area has secure footing, is clean and free from all debris and tools which may cause accidental tripping and/or falling.



## 2.18 TRANSPORT SAFETY

- The auger must be empty before raising or lowering the tube.
- Always transport auger in lowered position.
- Ensure all lights, reflectors, other lighting requirements are installed and in good condition.
- Never allow riders on the auger.
- Comply with all local laws governing safety and transporting equipment on public roads.
- Do not exceed a safe travel speed. Slow down for rough terrain and when cornering.
- Stay away from overhead power lines. Electrocutation can occur without direct contact.
- Plan your route to avoid heavy traffic.
- Do not drink and drive.
- Be a safe and courteous driver. Always yield to oncoming traffic in all situations, including narrow bridges, intersections, etc. Watch for traffic when driving near or crossing roadways.

## 2.19 STORAGE SAFETY

- Store the auger on a firm, level surface.
- Store in an area away from human activity.
- If required, make sure the unit is solidly blocked up.
- Remove the battery and store in dry location. Do not sit battery on a cold, concrete floor.
- Make certain all mechanical locks are safely and positively connected before storing.
- Do not permit children to play on or around the stored machinery.

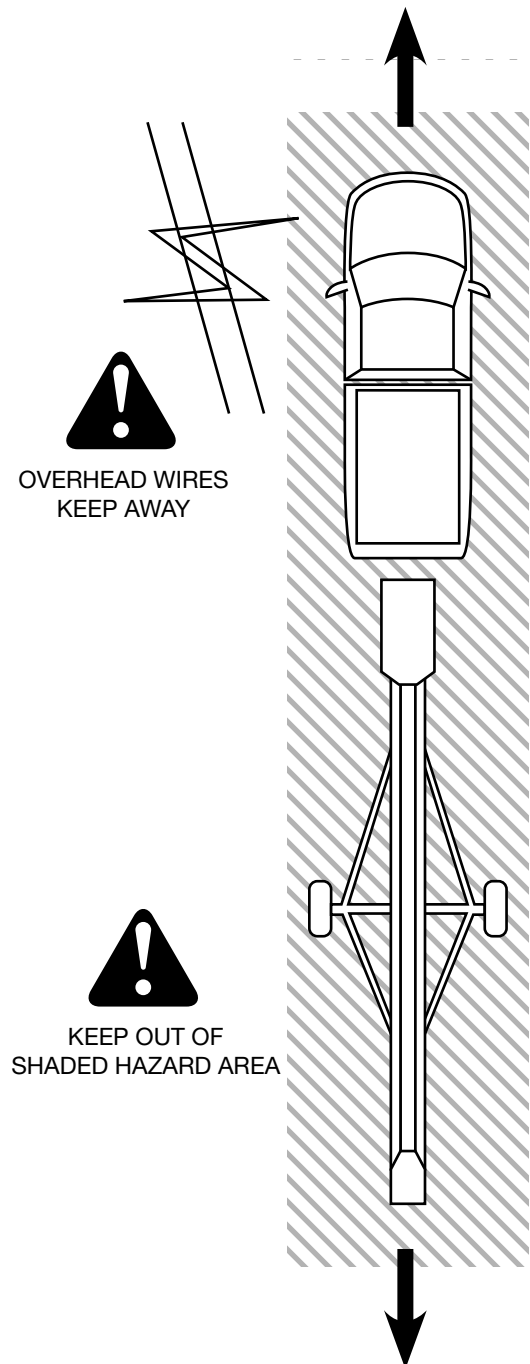

Fig 11 - Transporting Hazard Area

This page intentionally left blank

## Section 3: OPERATION

### WARNING

- Read and understand the Operator's Manual, and all safety decals, before using.
- Stop the engine/motor. Place all controls in neutral, remove ignition key and wait for all moving parts to stop before servicing, adjusting, or repairing or unplugging.
- Clear the area of bystanders, especially children, before starting.
- Keep working area clean and free of debris to prevent slipping or tripping.
- Keep hands, feet, hair and clothing away from all moving and/or rotating parts.
- Do not remove or modify auger flighting guards, keep in good working order.
- Do not operate the auger without all guards, doors, and covers in place.
- Do not allow riders on the auger.
- Stay away from overhead obstructions and power lines during operation. Electrocution can occur without direct contact.
- Chock wheels of auger before starting.
- Be familiar with the hazard area. If anyone enters hazard areas, shut down machine immediately. Clear area before restarting.
- Establish a lock-out, tag-out policy for the work site. Be sure all personnel are trained in and follow all procedures. Lock-out tag-out all power sources before servicing the unit.

The Meridian® auger has many features incorporated into it as a result of suggestions made by customers like you.

Hazard controls and accident prevention are dependent upon the personnel operating and maintaining the equipment. Their awareness, concern, prudence and proper training are crucial.

It is the responsibility of the owner and operators to read this manual and to train all personnel before they start working with the machine. By following recommended procedure, a safe working environment is provided for the operator, co-workers and bystanders in the area around the work site.

By following the operating instructions, in conjunction with a good maintenance program, your auger will provide many years of trouble free service.

### 3.1 MACHINE COMPONENTS

The truck load auger can be powered by a gas engine, electric motor or PTO.

- Components may vary, and their positions may change depending on the options which in the auger contains.
- Not all components appear on all augers.

Here is a list of the main components:

- a. Main Auger Tube with Drive Shaft
- b. Discharge
- c. Undercarriage
- d. Gearbox
- e. Optional Mover Kit
- f. Fork
- g. Reversing Gearbox linkage

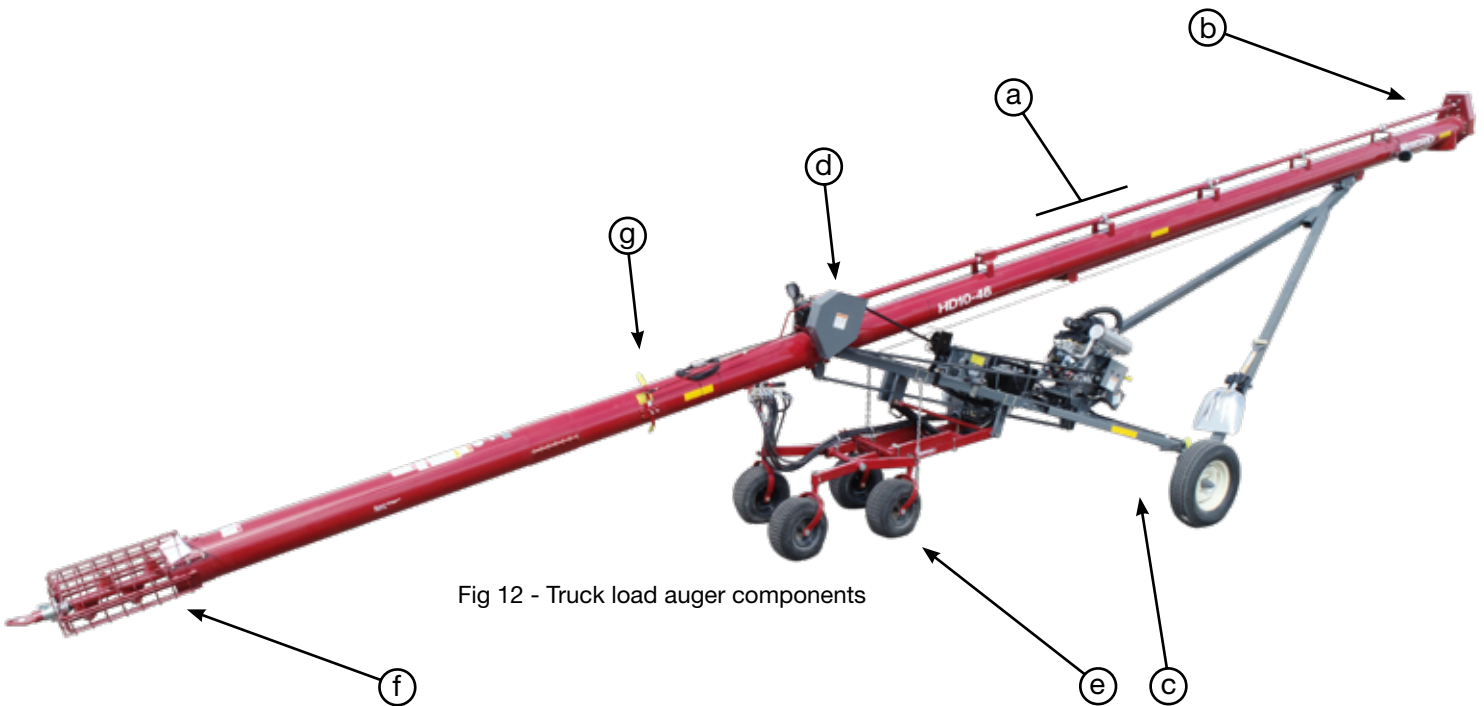

Fig 12 - Truck load auger components

## 3.2 COMPONENTS AND CONTROLS

### WARNING

#### ROTATING FLIGHTING HAZARD

- Do not operate with fork guard removed.
- Keep hands, feet, hair and clothing away from rotating flighting.
- Do not use a stick or pole to unplug intake while flighting is rotating.

#### Intake Fork:

The auger flighting is covered by a wire guard.



Fig 13 - Intake fork

#### Continuous Super-Edge™ Flighting:

This flighting is built into truck-load augers up to 53 feet. All Meridian augers are equipped with high capacity flighting.



Fig 14 - Undercarriage

#### Undercarriage:

Our truck-load auger is built with square, structural tubing, an offset axle, and self-leveling motor mount as standard features for rugged, dependable, operation.



Fig 15 - Discharge

#### Discharge:

Both drive shaft and flighting have greasable bearings. They are connected by sprockets and a chain at the discharge (head-end).

#### Gearbox with Pulley, and Drive Shaft:

This drive system which powers the flighting.

- The drive belt must be properly tensioned to run the drive shaft.
- The shaft sits on wooden pillow blocks.
- The Reversing Gearbox Linkage is standard on truck load augers. Use it to clean out the auger tube.

**Always** turn off engine before reversing gearbox.



Fig 16 - Gearbox and drive shaft

**Drive System:**

Available options include a gas engine, electric motor, or PTO. The drive uses either a banded double or triple V-belt.



Fig 17 - Drive belt and mover kit

**Four-Wheel Frame-Mounted Mover Kit (Optional):**

For unparalleled manoeuvrability, a mover kit is available to drive the auger on location.

- Refer to Section 3.3 for specific information about the mover.
- Use the handle bars to manoeuvre the steering wheels.
- Use the hydraulic levers to raise/lower the tube and steering wheels.



Fig 18 - Mover kit controls

**Truss System:**

The cable truss system is used on longer tube lengths. It needs to be adjusted periodically to keep it straight side-to-side, and a slight upward bow (a smile) in the auger tube for proper, long-lasting operation.



Fig 19 - Truss cables

### 3.3 FRAME MOUNT AUGER MOVER (if equipped)

To adjust your auger with mover:

1. Be sure all fittings are tight.
2. Fill the hydraulic reservoir with oil, to 1/2" below the bottom of the fill neck.
  - The oil used in factory is from BOSS Lubricants - industrial grade HVI 22 (viscosity index - HVI 22).
  - If another brand is used, verify with the supplier that it is compatible.
3. Check that the winch cable is tightened.
  - There must be at least 3 full wraps of cable on the drum before tension is applied.
4. Grease the hydraulic cylinder pin bosses.
5. Ensure all bolts are tight, pins are secure and cotter pins bent over.
6. Check that the mover tires have 8 - 10 PSI air pressure.
7. Check engine oil and coolant level on liquid cooled engines.
8. Start engine at a low RPM and let run for at least 3 - 5 minutes before actuating the lift cylinder.
  - This will allow the oil to circulate, to flush and trap any small particles in the return filter that could potentially plug the restrictor fitting on the lift cylinder.
9. After the initial 3 - 5 minute run, operate the 3 different functions and check for leaks.
  - **CAUTION:** Hydraulic oil under pressure can have enough force to penetrate the skin or eyes causing serious injury or possibly death.
  - Use safety glasses for eye protection.
  - Use a piece of heavy cardboard or wood to determine location of hydraulic leak.  
DO NOT USE YOUR BARE HANDS.
  - Keep open flame or sparks away to prevent an explosion or fire.

### 3.3.1 Lift Cylinder Relief Valve:

If the lift cylinder seeps down after the ball valve is locked, the lift relief valve may be set too low:

- Remove the cap from the cartridge.
- Using an allen wrench, turn the cap screw clockwise to increase pressure or counter-clockwise to decrease.
- Increase 1/8 of a turn and test.
- To test the setting, raise intake 4 feet off the ground and it should take about 300 - 400 lb of force to push the intake-end down to open the relief.
- **Note:** The engine should not be running while the cap is off.

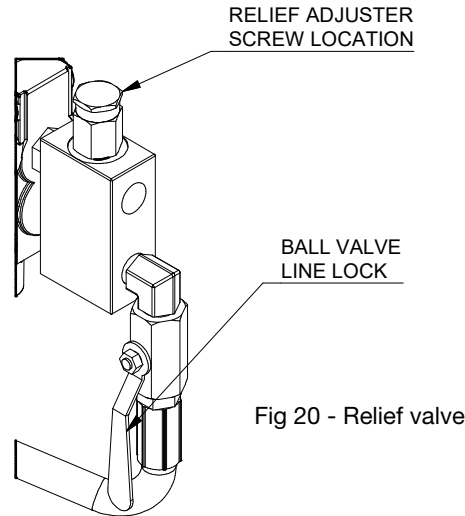

Fig 20 - Relief valve

### 3.3.2 Wheel Speed Needle Valve:

The wheel speed and traction force can be adjusted with the needle valve.

**Note:**

- Turning the needle valve all the way in will give full flow to the drive motors, but the controls will be very positive.
- The normal setting is to turn the needle valve in all the way, and then back it out one turn.
- Do not back out more than two turns otherwise the valve may leak externally.

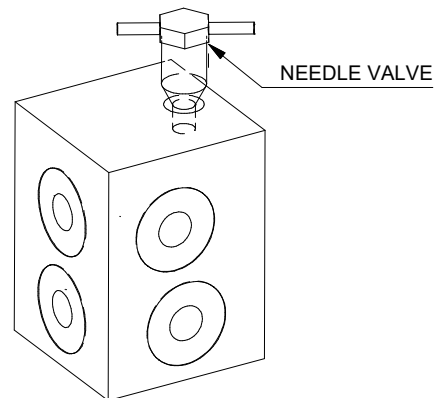
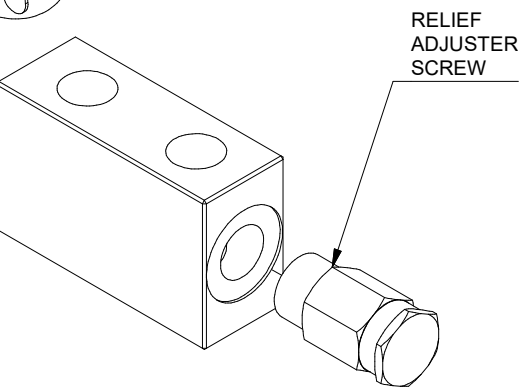
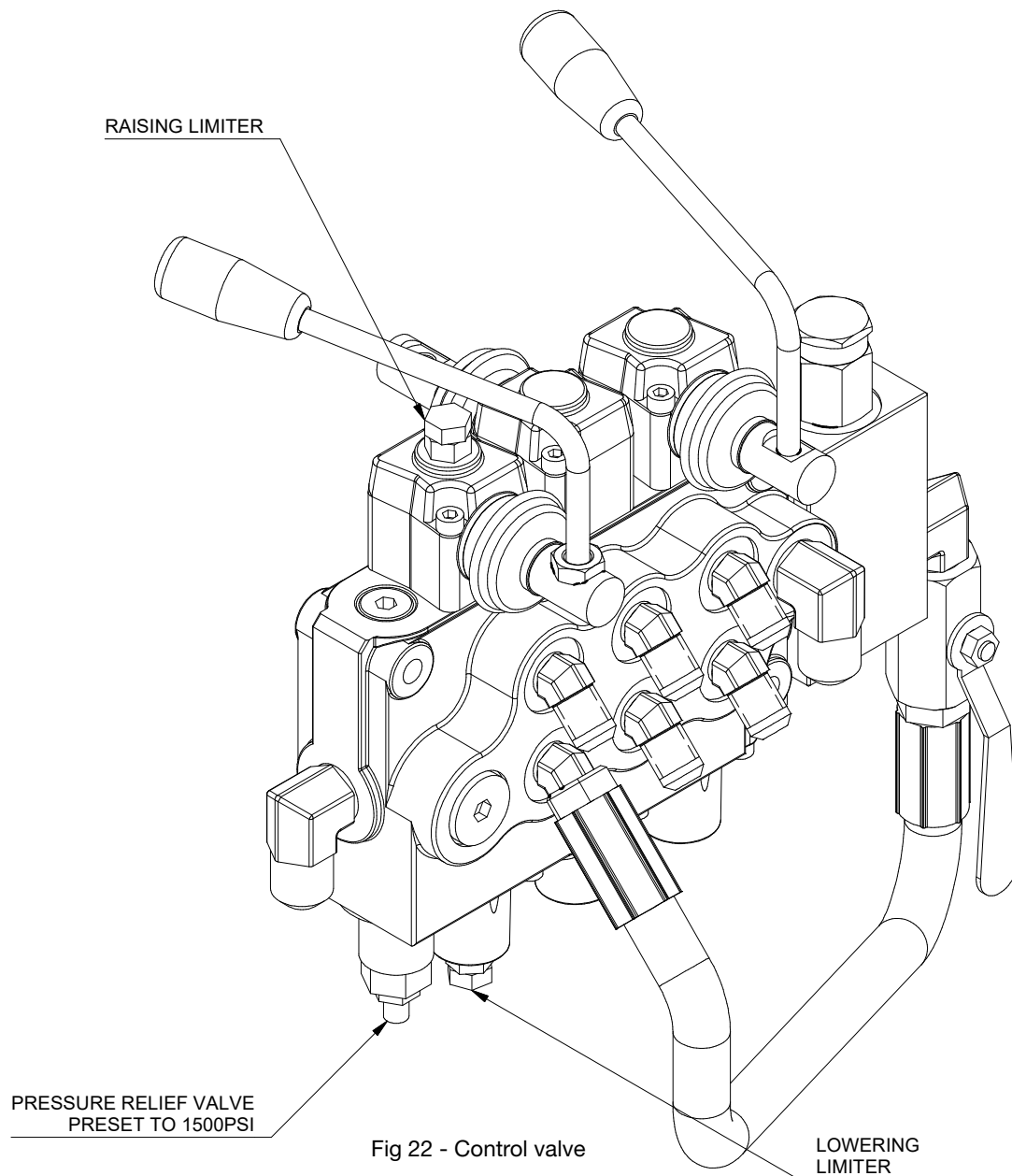

Fig 21 - Needle valve

### 3.3.3 Three Spool Control Valve:

This valve is equipped with a pressure relief valve that has been preset to 1500 PSI. The lift spool may require travel adjustment with the limit stops that are built into the bonnet on each end of the spool.

- To decrease the cylinder lift speed; remove the rubber cap, loosen the jam nut, and turn the limit screw in at the top of the lift spool.
- The limit screw at the bottom of the lift spool is to limit the speed of lowering.
- The desired setting with the engine running at 1/2 to 3/4 throttle is approximately 2 seconds per inch of cylinder rod travel.
- **Note:** If the lift spool is allowed to travel too far, the engine may start to labour.
  - This is due to the required restrictors in the two fittings on the lift cylinder.



### 3.4 TRANSPORTATION

#### **DANGER**

##### ELECTROCUTION HAZARD

- This auger is not insulated.
- Be alert to overhead obstructions and electrical wires. Electrocution can occur without direct contact.
- Do not raise or lower auger until hazardous area is cleared.
- Failure to maintain proper clearance can result in serious injury or death.

##### **IMPORTANT:**

If auger wheels are stuck in grain, mud, dirt, or snow, remove the restraining material before transport. Failure to do so could damage the auger.

1. Remove wheel chocks, so wheels are free to move.
2. All Meridian augers have minimum clearance positions when in transport mode.
  - The auger must be fully lowered.
3. Insert the hitch, and secure the pin in place
  - Ensure that the safety chain is properly attached.
  - Use a type of hitch pin that will not allow the auger to detach itself from the tractor.
4. If equipped, store PTO driveline and lock it into place.
5. If the auger is equipped with a light package, make sure the connections are fastened securely and not dragging on the ground.
6. Do not allow riders on the auger.
7. Transport the auger no faster than 24 km (15 mph).
  - When roads are rough or surfaces are uneven, slow down to ensure safe travel.
8. DO NOT transport the auger on slopes greater than 20 degrees. This could cause the auger to tip, resulting in damage.
9. When visibility is reduced, use caution and add extra lights to the auger.
10. Use extreme caution when turning or cornering with the auger in tow.
11. Check regulations with local authorities regarding auger transportation.
  - Equip the auger with all necessary lighting, and use hazard warning flashers on your pull-vehicle when required by law.

### 3.5 NEW MACHINE BREAK-IN

Meridian Manufacturing Inc. recommends that before you start moving grain with a new auger that you should do the following:

1. Double-check that the intake is properly positioned. If auger is equipped with PTO, the tractor's PTO drive is in OFF position.

#### NOTICE

When starting the auger for the first time, be prepared for an emergency shutdown in case of excessive vibration or noise.

- It may run roughly until tube is polished.
2. Run the auger at approximately 1/2 the normal operating speed (refer to Table 1, in Section 3.8.4). without adding grain to the fork for approximately 5 minutes.
  3. Bring auger up to full operating speed (refer to Table 1).
    - Slowly add grain to the fork.
  4. Continue to add grain slowly until approximately 1000 bushels (28 tonnes) has been run through the auger.
    - This will "shine up" the flighting and tube.
  5. The operator should be attentive to any unusual vibrations or noises.
    - Find the source.
    - Turn off and LOCK-OUT power source.
    - Adjust the auger until it runs smoothly.
  6. Upon completion of initial run, slow down until the tube is empty of product, then stop the auger.
    - Lock out the power source and conduct a complete inspection of the auger, following the pre-operation checklist.
    - After the initial start up and inspection, the auger should be shut down and inspected at least three times during the first hours of operation.

### 3.6 PRE-OPERATION CHECKLIST

Efficient and safe operation of the auger requires that each operator knows the operating procedures.

It is important for both the personal safety and maintaining the good mechanical condition of this machine that this checklist is followed

Before operating the auger, the following areas should be checked:

- All safety shields are in place, secure, and in good working order.
- Cables and fasteners are secure.
- Drive belts are in good condition and are tensioned correctly.
- Engine and gearbox are filled with oil.
- PTO driveline is securely attached to driveshaft and tractor.
  - PTO driveline telescopes easily and rotates freely.
- Tube is straight.
- Auger wheels and tractor wheels are chocked.
- Fork and discharge spout are free of any obstructions.
- A second qualified person is present during operation.
- All operators have read manual and are aware of safety precautions.
- Maintenance has been performed properly.
- Power to PTO and hydraulic system is in off position before starting tractor.
- Hydraulic system has been thoroughly checked for leaks.

### 3.7 AUGER PLACEMENT

Once the auger has been transported to the work site, it can be moved to its working position.

#### DANGER

##### ELECTROCUTION HAZARD

- This auger is not insulated.
- Be alert to overhead obstructions and electrical wires. Electrocution can occur without direct contact.
- Do not raise or lower auger until hazardous area is cleared.
- Failure to maintain proper clearance can result in serious injury or death.

1. Before raising or lowering your auger, check that the area is clear of obstructions, children and unauthorized personnel.
2. Ensure that your auger is on level ground that is free of debris.
  - If ground is very uneven, auger can tip and cause damage to the equipment.

#### WARNING

Never place risers under the wheels of the auger to increase height. This includes: wood, cement blocks, bricks, etc. Attempting this could result in damage to equipment and personal injury or death.

3. Ensure the auger wheels are free to move before raising or lowering the auger.
  - Remove dirt, snow, grain, etc. which may obstruct the auger movement.

4. Be sure the hitch is secured to the tractor.
5. Move the auger intake into place under a bin or trailer hopper.
6. Raise auger to desired height.
7. When the auger is in position:
  - Chock the auger wheels on both sides.

#### NOTICE

Never use the auger as a hoist or crane. This may damage the auger and void the warranty.

##### 3.7.1 Once work is complete:

8. Be sure auger tube is empty.
9. Remove wheel chocks and ensure area is clear of personnel and obstructions.
10. Be sure that the wheels are free to move.
11. Move the auger slowly away from under the bin or storage facility.
12. Lower the auger to its fully lowered position before transporting.

### 3.8 OPERATING ON SITE

#### **⚠ WARNING**

##### OPERATION HAZARD

- Keep hands, clothing, and other objects away from intake, drive chains, and all moving parts to avoid personal injury.
- Never use your hands to clean out debris.

#### **NOTICE**

##### HIGH WIND HAZARD

Do not operate or leave auger fully raised, in high winds. It may blow over, damaging structures and equipment.

#### **⚠ CAUTION**

##### POWER TAKE-OFF SAFETY

- Maintain a minimum 4 inch overlap on the tumbler shields.
- Do not engage PTO until all personnel are clear of tractor, tumbler shaft and auger.
- Ensure ends are fastened securely to the auger and tractor.
- When installing PTO, ensure CV end goes to tractor.
- Do not move auger with PTO driveline attached to the tractor.

#### 3.8.1 Auger Drive Systems and Lock-Out:

Proper operation of this auger requires that the operator pre-inspect the drive system, know how to shut down the system in an emergency, and generally monitor the system during operation.

##### • **Electric Motor:**

- Electric motors and controls must be installed by a qualified electrician and must meet the standards set by the National Standards Electrical Code.
- A magnetic starter should be used to protect the motor.
- The motor must have a manual reset button.
- Always disconnect power before resetting the motor.
- Reset and motor controls must be located so the operator has full view of the entire operation.
- Keep all guards and shields in place.

##### **Lock Out:**

- A main power disconnect switch capable of being locked only in the OFF position shall be provided.
- It must be locked whenever work is being done on the auger.

##### • **Gasoline Engine:**

- Never attempt to adjust or service engine while it is in operation.
- Shut-down and allow engine to cool before filling it with fuel.
- Keep all guards and shields in place.

##### **Lock Out:**

- Engines with ropes or crank start - remove spark plug wire or spark plug.
- Engines with electric start - remove ignition key, spark plug wire or spark plug.

##### • **PTO Driveline:**

- Never use a PTO Shaft without a rotating shield in good working order.
- Safety shields must be in place at the auger gear box and the power source.
- Ensure that the PTO drive on the tractor is in the OFF position before starting the tractor.
- Stay clear of PTO hazard area.

##### **Lock Out:**

- Turn off and remove ignition key from tractor.
- If the key can not be removed, remove the PTO driveline from the tractor.

### 3.8.2 Emergency Shut-Down:

1. Should the auger be shut-down under load, lock-out the power source.
  - Disconnect the PTO shaft.

#### **IMPORTANT:**

Never use your hands to clean out product from the auger. use a small shovel or other tool.

2. Reverse the gearbox, using the linkage shifter handle.
  - **Note:** Start the auger, at a reduced speed to avoid damage.
3. Run the auger in reverse to clean out the auger tube.
4. Make sure the fork and discharge are free of any blockages.
5. Stop the auger engine, and shift the gearbox back to forward.
6. Start auger at a reduced speed.

### 3.8.3 Normal Shut-Down:

1. Be sure that the fork and auger tube are empty before stopping the unit.
2. Turn off engine, electric motor or PTO.
3. Remove ignition key from auger and tractor.
4. Lock-out power source or remove PTO shaft.

### 3.8.4 Everyday Operation:

1. Complete the pre-operation checklist.
2. Have another trained operator present to monitor the operation and help with a shutdown in case of an emergency.
  - Monitor the auger during operation for vibration and abnormal noises.
  - If anything out of the ordinary is noted, shut-down and lock-out the auger.
  - Determine the source, and correct before continuing operation.
3. Observe work area restrictions.
  - Refer to Workplace Hazard Area diagram.
4. Keep all safety guards and shields in place.
5. Keep hands, feet away from all moving parts.
6. Run at correct speed for maximum capacity.

Table 1 - Auger Operating Speeds

AUGER SIZE	SPEED (RPM)
HD8	530
TL10	425
HD10	425
TL12	375

7. Run the auger only when moving material.
  - Running the auger without grain moving through it causes unnecessary wear.
8. Lock-Out power source to adjust, service or clean the auger.
9. Make certain everyone is clear before operating or moving the machine.

### 3.9 STORAGE

After the season's use, or when the auger will not be used for an extended period of time, it should be thoroughly inspected and prepared for storage.

Repair or replace any worn or damaged components to prevent unnecessary down-time next season.

For a long, trouble-free life, this procedure should be followed when preparing the machine for storage:

1. Remove all left over product or residue from the fork and inside tube.
2. Remove barriers, anchors and wheel chocks.
3. Disengage the engine, electric motor or remove the PTO shaft.
4. Move auger slowly out of work area.
5. Lower the auger to transport position.
6. Wash the entire machine thoroughly using a water hose or pressure washer to remove all dirt, mud, debris or residue.
  - Clean inside the tube.
7. Inspect all hydraulic hoses, fittings, lines, couplers and valves.
  - Tighten any loose fittings.
  - Replace any hose that is badly cut, nicked or abraded or is separating from the crimped end of the fitting.
8. Lubricate all grease fittings.
  - Ensure all grease cavities have been filled with grease to remove any water residue from having been washed.
9. The auger should be stored in transport position.
10. Do not attempt to pull auger out of snow bank in winter.
  - This will cause damage.
11. Ensure that there is no snow build up on the auger while in storage to prevent damage.

#### **WARNING**

##### STORAGE HAZARD

- Do not leave auger in raised position when not in use. Auger could drop rapidly in case of hydraulic failure.
- High winds may upset the auger.



Fig 23 - Auger in transport position

This page intentionally left blank

## Section 4: SERVICE AND MAINTENANCE

### WARNING

- Review the Operator's Manual and all safety items before maintaining the auger.
- Clear the area of bystanders, especially children, before repairing or adjusting.
- Before servicing, repairing or unplugging; place controls in neutral, stop engine, remove ignition key and wait for moving parts to stop.
- Follow good shop practices:
  - Keep service area clean and dry.
  - Be sure electrical outlets and tools are properly grounded.
  - Use adequate light for the job at hand.
- Relieve pressure from the hydraulic circuit before servicing.
- Before applying pressure to a hydraulic system, make sure all components are tight. Hoses and couplings are in good condition.
- Keep hands, feet, hair and clothing away from all moving and/or rotating parts.
- Make sure there is plenty of ventilation.
  - Never operate engine in a closed building.
  - Exhaust fumes may cause asphyxiation.
- Place stands or blocks under frame before working beneath the unit.
- When maintenance is complete, before resuming work, install and secure all guards.
- Keep decals clean, replace if not readable.

By following the operating instructions, in conjunction with a good maintenance program, your auger will provide many years of trouble free service.

### 4.1 FLUIDS AND LUBRICANTS

#### **Fuel and Engine Oil (if equipped):**

Refer to the engine's operator manual for specific information.

#### **Grease:**

Use an SAE multipurpose high temperature grease with extreme pressure (EP) performance. Also acceptable, SAE multipurpose lithium based grease.

#### **Hydraulic Oil:**

The factory uses oil from BOSS Lubricants - industrial grade HVI 22 (viscosity index - HVI 22).

- If another brand is used, verify with the supplier that it is compatible.

### Storing Lubricants:

Your machine can operate at top efficiency only if clean lubricants are used. Use clean containers to handle all lubricants.

- Store them in an area protected from dust, moisture and other contaminants.

#### 4.1.1 Greasing:

### NOTICE

#### GREASING HAZARD

- Too much grease causes excessive overheating.
- Under-greasing accelerates equipment wear.
- No grease should be seen around bearings.
  - If there is, too much grease was applied and the seal has ruptured!

#### IMPORTANT:

- Grease bearings only one pump per month under normal usage conditions.
- Bearing greasing frequency should be determined by usage and conditions.



1300006014

Fig 24 - Lubricate decal

1. Use a hand-held grease gun for all greasing.
2. Wipe grease fitting with a clean cloth before greasing, to avoid injecting dirt and grit.
3. All bearings are greasable, but require only minimal grease.
  - Recommended greasing is one small stroke every month.
  - Be careful not to over-grease as this may push the seal out.
4. Repair or replace broken fittings immediately.
5. If fittings will not take grease, remove and clean thoroughly.
  - Also, clean lubricant passageway.
  - Replace fitting if necessary.

## 4.2 SERVICING INTERVALS

The following recommended periods are based on normal operating conditions. Severe or unusual conditions may require more frequent lubrication and oil changes.



Schedules may vary depending on options and engine model contained in your equipment.



- Use this QR code to watch the preventative maintenance video.

- After maintenance is completed, replace and secure all safety shields, safety devices, service doors and cleanout covers. Refer to Section 2.15 for safety guard locations.

### 4.2.1 Every 10 Hours or Daily:

1. Check engine oil level.
  - Servicing and changing oil should be followed according to the engine manual.
2. Remove PTO Driveline guard cover (if equipped).
  - Grease universal joint.
  - Lubricate the centre portion of the driveline on a yearly basis.
  - The first lube maintenance should be done in the first 16 to 24 hours of operation. Then follow a regular schedule of lubing.
  - Check PTO universal joint retain bolt and retighten if necessary.
3. Check and grease intake bushing.
  - **Note:** If the paint has turned black from heat, the bushing may need to be realigned or replaced.
  - Use this QR to watch a video.
4. Check alignment of the drive shaft.
  - Shims may need to be added or removed.
5. Driveshaft pillow blocks are self-lubricating, but still should have one shot of grease.
  - **Note:** The steady bearing is sealed and does not require lubricating.
  - **Note:** Watch for signs of heat which could indicate a failed bearing and needs replacement.
  - Use this QR to watch a video.

6. Inspect the drive belt for frays, uneven wear and proper tension.
  - Use this QR to watch the video.



7. Inspect the hydraulic pump belt for frays and proper tension.

8. Inspect the winch cable for frays and kinks.
  - The cable should spool properly in the winch.
  - Cable clamps must be secure.
  - Use this QR code to watch the video on replacing the cable.



### 4.2.2 Every 50 Hours or Weekly:

9. Check hydraulic oil level.
  - The oil level should be kept to 1/2" below the bottom of the fill neck.
  - **Note:** If the hydraulic oil is low, check for leaks and repair.
  - The oil used in factory is from BOSS Lubricants - industrial grade HVI 22.
10. The spring-loaded idler requires one shot of grease.
  - **Note:** Be careful not to over-grease and get onto the drive belt.
11. Lubricate the two pivot points at the axle and frame.

**4.2.3 Every 200 Hours or Annually:**

12. Check the condition and tension of the head-end drive chain and sprockets.

- Using the mover, lower the head-end down to chest level.
- Adjust chain tension, if needed. **Do Not** over-tighten.
- Use this QR to watch a video.



13. Lubricate the head-end chain and sprockets with #130 gear oil at least once a year and more often if used commercially.

- Using a paint brush works well.
- **IMPORTANT:** Do not over-saturate with oil.

14. Grease the head-end bearings.

- **Note:** If auger is used commercially, grease bearings every three months.

15. Check gearbox oil level twice a year, even if there are no visual signs of an oil leak.

- Removing the plug from the side.
- Due to condensation build up, change the oil yearly.

16. Change oil in the gearbox.

- Use synthetic blend 75W90 GL-5 gear oil.

17. Lubricate PTO Driveline centre portion.

18. Grease the Frame wheel hubs.

19. Grease the Frame pivot points.

20. Check and repack wheel bearings with grease.

- Use this QR to watch a video.



21. Tire pressures should be checked yearly.

- Check it more often if the auger is being transported to different locations.

22. If equipped with a mover kit:

a. Check wheel drive motors for proper gear engagement.

- Check it more often if the auger is moved frequently.
- Use this QR to watch a video.



b. Check hydraulic oil reservoir.

- Frame Mount Mover uses 38 litres.
- Change the oil once a year.

23. Truss Cable Adjustment:

- 33 - 46 ft augers do not have truss cables.
- 53 - 115 ft augers are equipped with truss cables. They need to be adjusted annually to keep an upward bow (a smile) in the auger tube.

- Refer to Section 4.3.7 for details.

- Use this QR to watch a video.



24. Adjust the Reversing Gearbox linkage so it shifts correctly.

- Use this QR to watch a video.



Table 2 - Gearbox Oil Details

AUGER	PART #	DESCRIPTION	QUANTITY
HD8	13000001403	Gearbox	600 mL (20 oz)
	13000001403R	Reversing Gear Box	250 ml (8.5 oz)
TL10	13000002858	Gearbox	600 mL (20 oz)
	13000002858R	Reversing Gear Box	250 ml (8.5 oz)
HD10	13000001540	Gearbox	1500 mL (51 oz)
	13000001540R	Reversing Gear Box	500 ml (17 oz)
TL12	13000003231	Gearbox	1500 mL (51 oz)
	13000003231R	Reversing Gear Box	500 ml (17 oz)

## 4.3 MAINTENANCE PROCEDURES

### NOTICE

Replacement parts are not lubricated.  
When you receive these parts,  
be sure to lubricate and tighten screws.

- Before performing maintenance, shut down, lock out all power, and remove the ignition key.
  - Disconnect the PTO driveline from the tractor.
  - Always replace damaged or worn parts before using the auger.
  - Use only replacement parts manufactured by Meridian.
    - Use of unauthorized parts will void the warranty of your auger.
    - Contact your Meridian dealer to order parts.
  - Meridian Augers are designed and tested for a safe, efficient operation.
    - Do not modify the equipment in any way.
    - Modifications to the auger can create an unsafe working condition, affect the life of the equipment, and will void your warranty.
  - Support the auger tube before attempting maintenance on the undercarriage.
  - The auger should be in its transport position before attempting maintenance.
- ### 4.3.1 Drive Shaft Pillow Block Replacement:
1. Remove the carriage bolts from the drive shaft, pillow block bearing housing.
  2. Open the split housing and remove the pillow block(s).
    - **Note:** If the block is solid, instead of split (two pieces), it will need to be broken in half to be removed.
    - Use a hammer and chisel to break it.
  3. Insert the new split pillow blocks, around the drive shaft, and sit on the housing.
  4. Install the grease fitting into the split block.
    - It will anchor the block and facilitate lubrication.
  5. Fasten the housings over the pillow block bearing, onto the auger tube mount.
  6. Check alignment of the drive shaft.
    - **Note:** Shims may need to be added or removed from below the housing to achieve proper alignment.
  7. Grease the pillow block bearing.

### 4.3.2 Drive and Pump Belt Replacement:

1. Disengage the engine over-centre cam.
2. Remove the pump belt and clutch guards.



Fig 25 - Engine over-centre cam

3. Disconnect the clutch wiring harness from the clutch
4. Disconnect the rubber link from the clutch.
5. Open the belt guard at the gearbox.
6. Remove the drive belt from the gearbox pulley, then from the clutch pulley.
7. Disengage the pump over-centre cam.
  - Remove the pump belt.



Fig 26 - Clutch wiring harness

8. Install a new pump belt.
  - Engage the pump over-centre cam.

**Note:**

Calculate the belt tension (see Figure 29):

- Measure the length of span between pulleys.
- Allow 1/64" of deflection per inch of span.

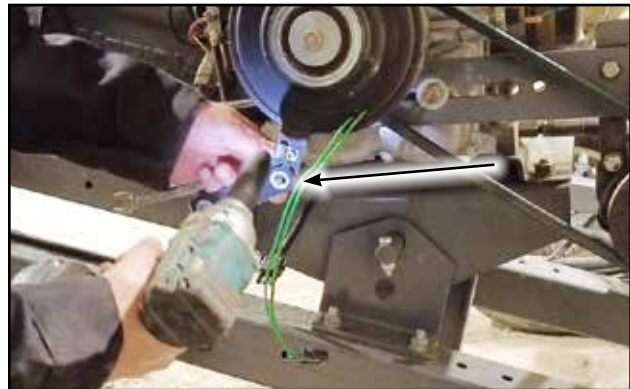

Fig 27 - Disconnect rubber link from clutch

9. Check the pump belt tension.
  - If belt adjustment is required:
    - a. Loosen the two mounting bolts on the slotted mounting bar.
    - b. Slide the slotted bar ahead or back to attain required setting.
    - c. Re-tighten the bolts.

10. Install the new drive belt over the clutch.
  - Then around the gearbox pulley.



Fig 28 - Open gearbox belt guard

11. Lift the spring idler pulley up and place it over top of the belt to hold it down.
12. Reconnect the rubber link to the clutch.
13. Reconnect the clutch wiring harness.
14. Install the clutch and pump guards.
15. Engage the engine over-centre cam, to tighten the drive belt.

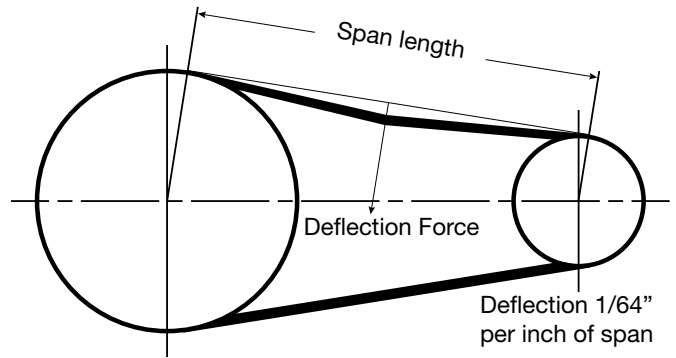

Fig 29 - Tension Calculation

16. Check the flight drive belt tension:
  - This is a long belt, measure the tension: Approx 10 lb of pull to lift the belt 1.9". This is the measurement for HD8-46.
  - If belt adjustment is required:
    - o Move the levelling bar which is a large turnbuckle. This will tilt the engine forward or back.

**Note:** In some cases, the engine may have to be adjusted using the slotted engine mounting plate. This will keep the engine from being tilted at too great of an angle.

17. After the new belt has run about 5 - 8 hours, the tension needs to be checked again.
18. The belt is now classified as an “After Run-In” belt and can be set to 7 lb / 1.9” deflection.



Fig 30 - Pump belt and over-centre cam



Fig 31 - Spring idler pulley

Table 3 - Tension settings for other auger sizes

Auger Size	Inch Deflect.	Run-In	Normal (after Run-In)
HD8-39	1.5"	10 lb	7 lb
HD8-46	1.9"	10 lb	7 lb
HD8-53	2.2"	10 lb	7 lb
HD8-59	2.5"	10 lb	7 lb
TL10-39	1.5"	15 lb	10.5 lb
HD10-46	1.9"	15 lb	10.5 lb
HD10-53	2.2"	15 lb	10.5 lb
HD10-59	2.5"	15 lb	10.5 lb
TL12-39	1.5"	15 lb	10.5 lb



Fig 32 - Clutch and pump belt guards

### 4.3.3 Winch Cable Replacement:



Fig 33 - Winch cable route

#### **CAUTION**

Cover the battery with cardboard or heavy plastic to prevent the loose winch cable from contacting terminals and shorting out.

1. Start the engine, then run the winch to lower the auger completely.
  - Continue to run the winch to unwind the cable, giving it slack.
2. Remove cable clamps at the track stop (a).
  - (b) Pull the cable out from trolley roller.
  - (c) Pull it out from around the cable roller, on the main frame.
  - (d) Loosen off the retaining set screw outside the winch spool.
  - Remove the cable.
3. Wrap the new cable around the winch spool.
  - Push cable end out the side of the spool.
  - Secure the cable with the retaining set screw to the outside of the spool.
4. Lead the cable below and around top of the cable roller on the main frame.
5. Pull the cable up to the trolley roller.
  - Feed the cable below, then around the roller and out.



Fig 34 - Winch spool cable retainer

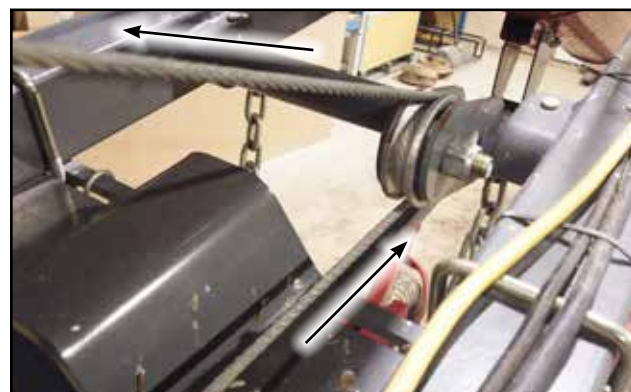

Fig 35 - Cable roller on main frame

6. Pull the cable into the track stop.
  - Add two cable clamps.
7. Feed the cable underneath, then around the top of the anchor pin.
  - Pull the cable back through the stop about 1 - 2 inches.

**Note:**

The cable must be looped around from the bottom, over the top of the anchor pin for proper cable clamp installation.

8. Thread the cable through the clamps inside the track stop.

**IMPORTANT:**

Position "U" of clamp over dead-end of cable.  
Live-end rests in saddle.

Tighten nuts evenly, alternate from one nut to other until recommended torque is reached.

9. Before operating the winch to tighten the cable, check to see that the new cable is still riding on the trolley roller and cable roller. If not, it could be damaged when being tightened up.
10. Start the engine and slowly operate the winch to take up the cable slack.

**Note:**

The cable should wind around the spool at least 2 - 3 times as it becomes tight.

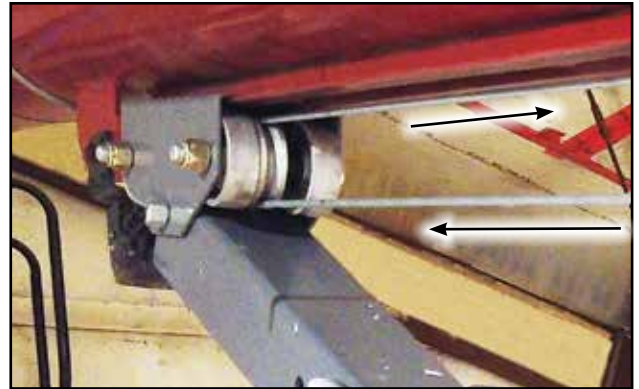

Fig 36 - Cable around trolley roller



Fig 37 - Track stop

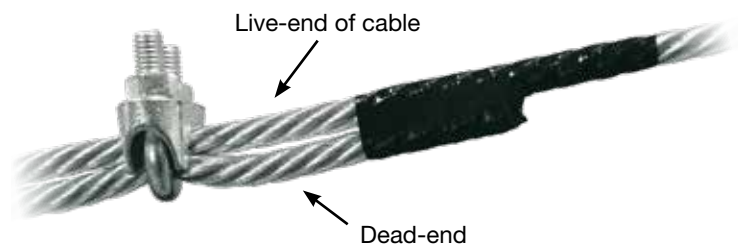

Fig 38 - Live-End and Dead-End of clamped cable

#### 4.3.4 Head-End Drive Chain and Sprockets:

1. Lower the head-end to chest level.
2. Remove the cover to inspect the chain and sprockets.
3. Check the condition of the chain and sprockets.
  - Replace if necessary.
4. Check the chain tension.
  - Adjust so that the drive chain tension has 1/4" deflection.
  - The upper sprocket bearing (connected to the drive shaft) has a slot in the head-end base plate. Use it to increase/decrease the head-end chain tension.
  - If more tension is required, a link in the chain can be removed.
5. Lubricate with gear oil at least once a year and more often if used commercially.
  - Using a paint brush works well.
6. Grease the head-end bearings.
  - **Note:** If auger is used commercially, grease bearings every three months.
7. Reinstall the chain cover after servicing.



Fig 39 - Inspect chain and sprockets

#### 4.3.5 Mover Drive Assembly Gear Adjustment:

There must be firm engagement between the drive motor pinion gear and the wheel ring gear. Both should be parallel with each other and 90° to the conveyor axle.

- The pinion gear is 3/8" wider than the ring gear.
- When engaged, the ring gear should sit in the centre. The pinion gear should be offset by 3/16" on each side.

To bring the pinion gear more into engagement with the ring gear:

1. Loosen the flange nut.
2. Pull the slotted handle up, which lifts the motor and pinion gear, to mesh with the ring gear.
3. Tighten the flange nut to a torque of 55 ft-lb.

Adjust the bolts around the assembly. They must be snug but not tight, the over-centre mechanism should be able to move.



Fig 40 - Engaged gears

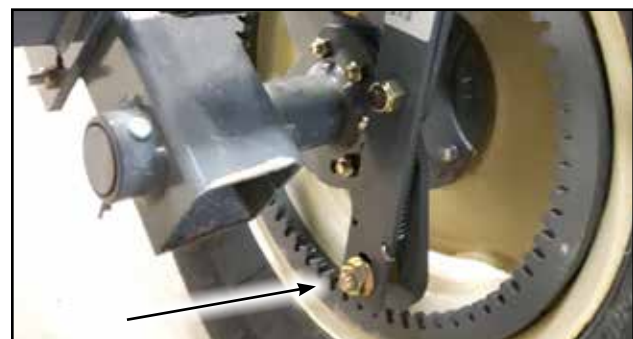

Fig 41 - Flange nut at bottom of assembly

#### 4.3.6 Repack Wheel Bearings:

### WARNING

#### PREVENT ACCIDENTAL MOVEMENT

Always chock the auger wheel which is not being worked on.

1. Using a jack, lift the axle on the proper side to work on that wheel.
    - **Note:** If equipped with a mover, disengage the drive assembly.
  2. Remove the 1/2 inch wheel bolts.
  3. Remove the dust cap.
  4. Remove the cotter pin, which holds the hex nut in place.
    - Twist off the hex nut.
  5. Remove the roller bearing and then the hub.
  6. Wipe the old grease and clean all the components well:
    - Spindle, hub, roller bearing, and hex nut.
  7. Wash the components with brake cleaner or solvent.
  8. Inspect the tapered roller bearing for damage. Replace if necessary.
- IMPORTANT:**  
Always use SAE multipurpose lithium-based grease.
9. Add high-quality grease to inside of hub.
    - Work it around the inside, throughout the rear bearing and the seal.
  10. Slide the hub onto the spindle.
  11. Apply grease to the roller bearing.
    - Work it around, inside and out.

12. Slide roller bearing onto spindle, inside hub.
13. Twist the hex nut into place.
  - a. Snug up the nut until a slight resistance is felt when turning the hub. This will seat the roller bearing.
  - b. Then, carefully back off the nut to the point when the hub can be turned freely.
  - c. Now, turn the nut back a little more until it's groove matches the closest hole, in the spindle, where the cotter pin will be inserted.
14. Insert a new cotter pin.
  - Bend the end of the pin to lock it in place.
15. Fill hub with new grease to cover bearings.
16. Clean dust cap and push it on to close hub.
17. Reinstall the wheel.
  - Fasten the bolts to a torque of 90 ft/lb.



Fig 42 - Fill hub with grease



Fig 43 - wheel on hub

**4.3.7 Truss Cable Adjustment:**

The truss cables require adjusting periodically as they will stretch over time and use. Simply transporting the auger from one location to another can cause the truss cables to stretch.

- The procedure for adjusting truss cables is basically the same for all auger models although the amount of adjustment may differ.
1. **IMPORTANT:** Lubricate the cable clamps (on the truss risers) and the eyebolt lock nuts (at the bottom of the cable), to prevent damage.
  2. Loosen cable clamps on the truss risers.
  3. Loosen the lock nuts on both eyebolts (at the bottom of the cables).
  4. To tighten the cables:
    - Slowly and evenly, tighten each eyebolt nut.
    - Two turns on one side, then two turns on the other side until required adjustment is achieved.
    - **IMPORTANT:** Hold the eyebolts to keep the cable straight.
  5. Once adjusted, there should be an upward bow (a smile) in the auger tube.
    - Look up the auger tube from the intake towards the discharge. The centre of the auger should be lower than the two ends.
    - **Note:** Refer to the table for measurements of the “smile” for different tube lengths.
  6. When the adjustment is complete, tighten the eyebolt lock nuts.
  7. Tighten the truss riser cable clamps.



Fig 44 - Cable clamps on truss risers



Fig 45 - Adjusting eyebolts at bottom of cable

Table 4 - Measurement of Rise at Discharge

AUGER LENGTH	“SMILE” IN THE TUBE (RISE AT DISCHARGE)
53 ft	2 to 3 in
59 ft	3 to 4 in
66 ft	3 to 4 in
72 ft	4 to 5 in
75 ft	4 to 5 in
79 ft	5 to 7 in
85 ft	5 to 7 in
95 ft	6 to 8 in
105 ft	6 to 8 in
115 ft	9 to 12 in

#### 4.3.8 Reversing Gearbox Linkage Adjustment:

The shifter handle is used to change the direction in which the gearbox runs.

- Pull the pin below the handle to move it in the desired direction.
- The handle should be in neutral before making adjustments to the linkage.

1. After the shifter handle has been installed to mounting bracket on the tube, the linkage rod and clevis are to be installed to the top hole of the shifter handle.
  - The lock nuts can be left loose at this time.
  - The handle should also be in neutral.



Fig 46 - Shifter handle

2. Move the gearbox lever all the way from one side to the other and measure to find the centre (neutral) position.
  - **Note:** The centre detent may not be exactly in the middle so measuring is a more accurate way to determine neutral.

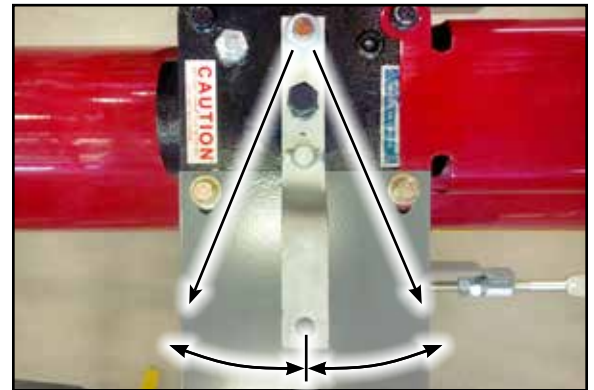

Fig 47 - Gearbox lever in neutral position

3. Once neutral has been established, a rough adjustment can be made by sliding the rods in or out and locking with the two set screws.
  - Depending on length of auger you may have two rods with set screws to adjust and lock.



Fig 48 - Set screws to lock rods in place

4. The final adjustment is made by turning the clevis at the gearbox until a drop fit of the clevis pin is made.
5. Install cotter pins to the clevis pins and tighten all jamb nuts.



Fig 49 - Rod and linkage installed

### 4.3.9 Mover Pump Hydraulic Schematic:

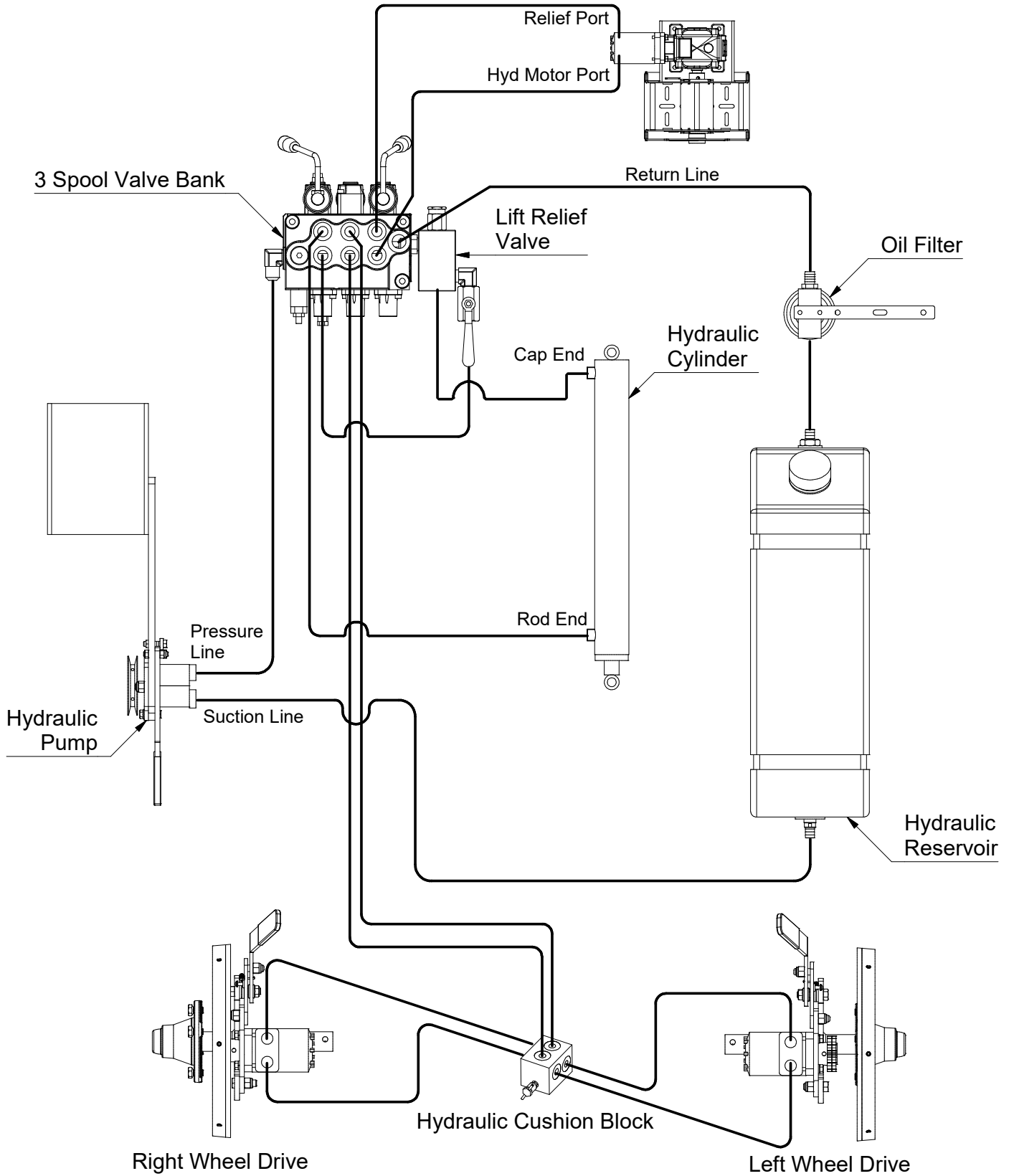

#### 4.3.10 Change Hydraulic Oil:

The factory uses BOSS Lubricants - industrial grade HVI 22.

**IMPORTANT:** Do not mix oil types.

Oil tank capacity is 38 Litres (10 US Gal).

### **WARNING**

#### HOT LIQUID HAZARD

Allow hydraulics to cool before changing oil.  
Hot oil will burn if it contacts exposed skin.

#### **IMPORTANT:**

- Annually, have an oil sample tested for particle count.
- Change oil only if necessary.

1. Allow the hydraulics to cool slightly before changing oil.

#### **Note:**

It is best to change oil while the engine is warm (not hot) to keep contaminants in suspension.

2. Place a large pan or pail under the drain plug. The amount of oil is 38 L (10 US Gal).
3. Remove drain plug and allow to drain for 10 min.
4. Install and tighten the drain plug.
5. Dispose of the used oil in an approved container and manner.
6. Fill the hydraulic tank with specified oil.

#### 4.3.11 Change Hydraulic Oil Filter:

1. Place a pan under filter to catch any spilled oil.
2. Remove hydraulic oil filter, and dispose of it.
3. Apply a light coat of oil to the O-ring and install the new filter. Snug up by hand and then tighten another 1/2 turn.
4. Run the engine for 1-2 minutes and check for oil leaks.
5. If leaks are found around the drain plug or filter, tighten slightly.
6. Check oil level. Top up as required.



This page intentionally left blank

## Section 5: TROUBLESHOOTING

This section contains a list of common problems, causes and offers quick solutions to those issues. If problems are confronted which are difficult to solve, even after having read through this section, please contact your authorized dealer, distributor or Meridian manufacturing Inc.

### ***Problem***

Possible Cause	Possible Solution
----------------	-------------------

### *Flight not turning.*

Chain disconnected in headend.	Reinstall drive chain with connector link.
Key sheared on flight drive sprocket.	Install new key on flight drive sprocket.
Key sheared on drive shaft sprocket.	Install new key on drive shaft sprocket.
Broken stub shaft at top end of drive shaft.	Replace top drive shaft assembly.

### *Drive shaft not turning.*

Chain coupler comes apart from coupler sprockets between gearbox and bottom end of drive shaft.	Reinstall coupler chain with connector link onto the coupler sprockets.
Key missing from coupler sprocket on bottom of drive shaft.	Install new key on coupler sprocket on bottom of drive shaft
Key missing from coupler sprocket on gearbox output shaft.	Install new key on coupler sprocket on gearbox output shaft.

### *Gearbox output shaft not turning.*

Shifter handle loose on top of gearbox.	Re-tighten retaining nut on shifter handle to ensure handle is tight to shifter shaft.
Shifter linkage not correctly adjusted.	Adjust shifter linkage to ensure shifter lever is moving fully forward and reverse.
Failed gearbox.	Install new gearbox with gear oil.

### *Gearbox input shaft not turning.*

Key on drive pulley and input shaft missing.	Install new key on drive pulley and input shaft.
--	--

continued on next page

*Auger flight is noisy and vibrates.*

If auger is new the tube and flight need to be polished.	Running product through auger will polish the tube and flight to reduce friction and noise.
Tube made incorrectly with seam at the bottom.	Replace with correctly made tube with seam at the top.
Flight made incorrectly causing out of balance and interference to tube.	Remove flight to check for out of balance and replace with new if required.
Check tube for dents.	Repair dents or replace tube.
Check tube for drooping downwards.	Tighten truss cables to lift head end up (smile).
Intake bushing worn.	Replace intake bushing and lubricate.
Topflight bearing worn out.	Replace topflight bearing assembly.
Bent forks forcing flight to one side.	Replace forks.
Foreign object drawn into flight.	Check for foreign object and remove.

*Intake flight bushing heating up.*

Lack of grease at intake bushing.	Grease intake bushing.
Intake bushing on fork end worn.	Replace intake bushing fork end.
Intake bushing out of alignment.	<ul style="list-style-type: none"> <li>• Check for damaged or bent forks and replace.</li> <li>• Add shims to align bushing on fork end.</li> </ul>

*Gearbox is noisy.*

Input or output shaft bearings bad.	<ul style="list-style-type: none"> <li>• Check for oil leaking past seals on input and output shafts.</li> <li>• Side movement on the input or output shafts would indicate worn bearings.</li> <li>• Replace worn bearings and seals.</li> </ul>
Low on gear oil.	Check oil level and add as required.
Shifter out of adjustment.	Adjust shifter linkage to ensure shifter lever is moving fully forward and reverse. (See Bulletin "Reversing Gearbox Linkage Adjustment" PN 130000072784-00)

*Winch got harder to lift.*

Auger full of product.	Empty auger.
Winch cable jumped off top cable roller and riding on track roller spacer.	Loosen off winch cable and lift back onto top cable roller.
Top cable roller seized to bushing.	Free up top roller and bushing and lubricate.
Lower cable roller seized to bushing.	Free up lower roller and bushing and lubricate.
Track rollers seized to bushings.	Free up track rollers and bushing and lubricate.

continued on next page

*Winch brake will not hold.*

Ratchet gear broken or missing teeth.	Replace ratchet gear.
Friction disks worn.	Replace friction disks.
Pawl and or spring broken or bent over	Replace Pawl and spring assembly or straighten back into place to align with ratchet gear.

*Winch grinds and will not lift.*

Gears and or bushings worn out causing gears to skip over each other.	Repair winch or replace with new winch.
---	---

*Auger drive belt slipping.*

Drive belt has become loose.	<ul style="list-style-type: none"> <li>• Adjust belt tension by leveling bar adjustment and tighten leveling bar jamb nut.</li> <li>• May need to move engine on mounting plate.</li> </ul>
Belt has got glazed through slippage.	Replace belt and adjust accordingly.
Belt has been contaminated with oil.	<ul style="list-style-type: none"> <li>• Repair gearbox oil leak and or engine oil leak.</li> <li>• Clean gearbox pulley and engine drive pulley.</li> <li>• Replace auger drive belt.</li> </ul>
Belt has jumped over top of idler pulley.	Place belt back under idler pulley.
Belt is out of alignment.	<ul style="list-style-type: none"> <li>• Align belt by adjusting power source to bring belt in alignment between power source and gearbox pulley.</li> <li>• May also need to adjust the gearbox pulley.</li> </ul>

*Auger drive belt is bouncing.*

Belt has jumped over top of idler pulley.	Place belt under idler pulley.
---	--------------------------------

*Auger drive belt will not stay under idler pulley.*

Idler pulley needs adjustment.	Adjust idler pulley to provide tension on back side of drive belt.
Idler pulley bearing worn causing pulley to wobble and run unstable.	Replace idler pulley and adjust.

*Difficulty moving engine over center to engage and or disengage drive belt.*

The over center cam assembly has become dry and or rusty.	Free up rust and lubricate the over center cam assembly.
---	--

continued on next page

*Noisy drive shaft.*

Pillow block bearings worn out.	<ul style="list-style-type: none"> <li>• Replace with new pillow block bearings and lubricate.</li> <li>• May need to replace drive shaft if excessive wear at pillow block surfaces.</li> </ul>
Steady bearing used on longer augers is worn out.	Replace with new steady bearing.
Drive shaft out of alignment.	Align drive shaft by adjusting pillow blocks side to side and up or down by adding or removing shim plates.
Drive shaft bent.	Replace drive shaft.

*Auger leans to one side when it fills with product.*

Low tire pressure on one side.	Check tire pressures on both wheels to bring up to proper pressure (32 PSI).
--------------------------------	--

**MOVER KIT ISSUES***Poor or no hydraulics.*

Pump over center disengaged.	Re-engage over center.
Slotted pump bracket moved.	Re-adjust bracket and tighten hardware.
Worn belt.	Replace with new belt.
Oil on belt.	Check for source of oil leak and repair and replace with new belt.
Low hydraulic oil in tank.	Top up hydraulic oil, check and or repair leaks.
Rubber seal from tank cap is drawn into the intake fitting.	Remove blockage from intake fitting.
Worn pump.	Replace with new pump.
Pump pulley slipping on pump shaft.	<ul style="list-style-type: none"> <li>• Install new key and set screws.</li> <li>• May also need a new pulley if worn and or new pump.</li> </ul>
Pump drive pulley slipping on engine crankshaft.	<ul style="list-style-type: none"> <li>• Install new key and set screws on pump drive pulley.</li> <li>• May also need a new pulley.</li> </ul>
Main relief valve.	Adjust main relief valve = 1500 PSI.

continued on next page

*Jerky hydraulics and noisy.*

Low on hydraulic oil.	Add hydraulic oil to bring up to proper level 1/2" below the filler cap.
Suction hose leak between hydraulic pump and hydraulic tank.	<ul style="list-style-type: none"> <li>• Tighten hose fittings, etc. between pump and tank.</li> <li>• <b>Note:</b> A suction leak will usually show up as an external oil leak when shut off.</li> </ul>
Rubber seal from tank cap is drawn into the intake fitting.	Remove blockage from intake fitting.
Hydraulic oil contaminated w/water or gas.	Drain and add new hydraulic oil and change filter.
Hydraulic pump seal leaking.	<ul style="list-style-type: none"> <li>• Replace seal on pump or complete pump.</li> <li>• <b>Note:</b> A leaking seal on the pump will usually show up as an external oil leak when shut off.</li> </ul>

*Weak drive force forward and reverse.*

Cushion block setting too low.	Turn needle valve all the way in clockwise and then back out counterclockwise 1/2 to 3/4 of a turn.
Worn out hydraulic pump.	Replace hydraulic pump.

*Loss of drive forward and reverse.*

Key missing from drive motor shaft and gear.	Install new key on drive motor shaft and gear.
Wheel gear came loose in wheel rim.	Reinstall wheel gear and retorque 6 set screws to 12 ft. lb. (144 in. lb.) in a crisscross pattern.
Worn out drive motor(s).	Replace drive motor(s) and changing of hydraulic oil and filter is recommended.

*Easily rolls away on incline when control is in neutral.*

Cushion block setting too low.	<ul style="list-style-type: none"> <li>• Turn needle valve all the way in clockwise, then back out counterclockwise 1/2 to 3/4 of a turn.</li> <li>• <b>Note:</b> If a more positive control is required to prevent roll-away, the needle valve can be turned all the way in and not backed out at all.</li> <li>• Caution must be taken when the needle valve is turned all the way in as the directional control will then be positive.</li> </ul>
Worn out drive motor(s).	Replace drive motor(s).

*Pump belt squealing.*

Belt is loose	Adjust slotted pump bracket to gain belt tension.
Belt is old and hard.	Replace belt.

continued on next page

*Intake seeps down.*

Line lock not engaged.	Engage line lock to locked position.
Lift relief valve set too low.	Adjust lift relief valve as per operator's manual. Refer to Section 3.3.2
Lift relief valve will not adjust.	Replace and adjust lift relief valve.
Lift cylinder leaking internally.	<ul style="list-style-type: none"> <li>• Check lift cylinder using the instructions; "Testing cylinder leak down belt augers".</li> <li>• Repair or replace leaking lift cylinder.</li> </ul>
Faulty line lock (ball valve).	<ul style="list-style-type: none"> <li>• Check line lock using the instructions; "Testing cylinder leak down belt augers".</li> <li>• Replace line lock.</li> </ul>

*Hydraulic winch will not lift auger.*

Auger full of product.	Empty auger.
Winch cable jumped off top cable roller and riding on track roller spacer.	Loosen off winch cable and lift back onto top cable roller.
Top cable roller seized to bushing.	Free up top roller and bushing and lubricate.
Lower cable roller seized to bushing.	Free up lower roller and bushing and lubricate.
Track rollers seized to bushings.	Free up track rollers and bushing and lubricate.
New style two port relief valve on winch malfunctioned.	Replace two port relief valve on winch.
Old style four port relief valve on winch malfunctioned.	<ul style="list-style-type: none"> <li>• Adjust to increase pressure on older four port relief valve.</li> <li>• If valve will not adjust, then replace relief valve.</li> </ul>
Winch motor weak (worn out).	Replace winch motor.
20:1 reduction winch failed (broken).	Replace 20:1 reduction winch.

*Grinding noise at wheel drive motor.*

Drive gear not in proper mesh with wheel gear.	Perform adjustment of wheel drive motor to attain proper engagement with wheel gear. (See Bulletin "Mover Wheel Motor Adjustment" PN 130000012782-00)
--	---

*Wheel drive motor will not stay engaged over-center.*

The over-center spring may have broken or become stretched.	Replace over-center spring and recheck adjustment of wheel drive motor. (See Bulletin "Mover Wheel Motor Spring Placement" PN 130000012782-00)
---	--

continued on next page

*Hard to steer.*

Tire pressure low on mover wheels.	Inflate 4 mover tires to 8-10 psi.
Two steering wheels out of alignment.	Adjust steering bar to align wheels.
One of the two steering wheels has broken stem to yoke and will not steer.	<ul style="list-style-type: none"> <li>Remove and replace complete steering yoke and wheel assembly.</li> <li>Readjust steering bar to realign two steering wheels.</li> </ul>

*Lift control will only work in one direction but not the other.*

Water has got into the bottom bonnet of the lift spool and has frozen into ice restricting spool travel into the bonnet.	Remove bottom bonnet of the lift spool and remove ice. Drill 1/16" hole in bottom of bonnet to prevent moisture being trapped in bonnet. Reinstall bonnet. (See Bulletin "Mover Spool Valve Drilling Bonnets" PN 130000012781-00)
Plugged restrictor fitting(s) on hydraulic cylinder.	Replace restrictor fitting(s) on hydraulic cylinder.

*Winch control will only work in one direction but not the other.*

Water has got into the bottom bonnet of the winch spool and has frozen into ice restricting spool travel into the bonnet.	Remove bottom bonnet and remove ice. Drill 1/16" hole in bottom of bonnet to prevent moisture being trapped in bonnet. Reinstall bonnet. (See Bulletin "Mover Spool Valve Drilling Bonnets" PN 130000012781-00)
---	---

*Travel control will only work in one direction but not the other.*

Water has got into the bottom bonnet of the travel spool and has frozen into ice restricting spool travel into the bonnet.	Remove bottom bonnet and remove ice. Drill 1/16" hole in bottom of bonnet to prevent moisture being trapped in bonnet. Reinstall bonnet. (See Bulletin "Mover Spool Valve Drilling Bonnets" PN 130000012781-00)
--	---

**ACCESSORY ISSUES***All lights quit working.*

Burnt fuse in light switch box.	<ul style="list-style-type: none"> <li>Locate and repair cause of fuse blowing in the light circuit wiring or switch box.</li> <li>Replace fuse.</li> </ul>
Poor ground wire connection.	Check for proper grounding of wire at engine mount.
	Check for ground connection in harness before the engine mount and at engine mount.
Poor connections in switch box.	Check connections in switch box to fuse holder and toggle switch.
Broken connection in main light harness.	Check, repair or replace main light harness.

continued on next page

*One light quit working.*

Light burnt out.	Replace light.
Poor connection at pin connectors.	Check and repair pin connectors.

*Three groove clutch cuts out or will not engage and may sometimes lead to clutch slippage resulting in plates turning purple or blue from heat.*

Low battery voltage.	Check battery voltage. Should be up to at least 13 to 14 volts while engine is running. If battery voltage is low, battery may need replacement and have charging system checked on engine.
Poor ground wire connection.	Check for proper grounding of wire at engine mount.
	Check for ground connection in harness before the engine mount.
Poor connection at pin connectors.	Check and repair pin connectors between main harness and clutch.
	Check connections in secondary switch box.
	Check for broken harness between the two switch boxes.
Soft start malfunction.	Check plug connection to soft start module. Try bypassing soft start and connect clutch switch harness directly to clutch. If clutch works, then replace soft start module. (See Bulletin "Soft Start Bypass" PN 130000012785-00)
Bad clutch - clutch failure.	Replace clutch.

*Three groove clutch fails due to electrical problems - Limp Home Feature.*

<p>In the event your clutch may fail due to electrical problems, there is an Over-Ride Clutch Kit.</p>	<p>Please find enclosed two small metric bolts (6mm x 12mm) used to manually lock your electric clutch pack. Install the two bolts on the pulley side of your clutch pack.</p>  <p>Bolt is 6mm x 12mm. Do not exceed bolt length or clutch will be damaged.</p>
--	---

continued on next page

*Two groove clutch cuts out or will not engage and may sometimes lead to clutch slippage resulting in plates turning purple or blue from heat.*

Low battery voltage.	Check battery voltage. Should be up to at least 13 to 14 volts while engine is running. If battery voltage is low, battery may need replacement and have charging system checked on engine.
Poor ground wire connection	Check for proper grounding of wire at engine mount.
	Check for ground connection in harness before the engine mount
Poor connection at pin connectors.	Check and repair pin connectors between main harness and clutch.
Poor connections in switch box.	Check connections in switch box to fuse holder and toggle switch.
	Check connections in secondary switch box.
	Check for broken harness between the two switch boxes.
Soft start malfunction.	Check plug connection to soft start module. Replace soft start module.

*Clutch vibrating.*

Loose clutch retaining bolt.	Tighten clutch retaining bolt.
Failed bearing(s).	Replace clutch assembly.
Bent engine crankshaft.	Repair or replace engine. Check belt and leveling bar for proper adjustment to prevent reoccurrence of bending crankshaft.

*Fuse blown on engine causing engine shut down.*

Battery connected incorrectly causing diode failure and a direct short to ground.	Disconnect battery. Install new diode. Reconnect battery positive to positive and negative to negative. Replace engine fuse.
---	--

*Engine runs poorly.*

Old gas.	Drain old gas and replace with new fresh gas.
Dirty air filter.	Replace with new air filter.
Gas contaminated with water.	Drain old gas and replace with new fresh gas.
Pinched or kinked gas hose.	Free up gas hose from kink or pinched area.
Gas restricted at fitting in tank.	Clean tank of foreign material at intake fitting.
Engine requires more extensive service.	Take engine to authorized repair depot.

continued on next page

*Hard starting in cold weather.*

Engine oil is too heavy.	Change oil to a lighter weight for cold weather. Refer to engine manual for recommendations.
Weak battery.	Charge up or replace battery.
Hydraulic pump is laboring engine when trying to turn over engine.	Disengage hydraulic pump by relaxing the over center lever. Once engine starts then re-engage the over center lever to run pump.

\* Remember to follow proper break-in procedures, refer to Section 3.6. The auger may run rough until the tube is polished. If noise is extreme from the outset or continuous after several loads of grain are fed, continue with troubleshooting.

## Section 6: REFERENCE

For information not included here, or for a digital copy of this manual, please call your dealer, or Meridian Manufacturing Inc. directly for assistance: (833) 944-2345.

Specifications and measurements are subject to change without notice.

Table 5 - HD Auger Details

	HD8 SERIES	HD10 SERIES
Auger Tube	8" OD x 14 Gauge	10" OD x 13 Gauge
Auger Flight	10 Gauge Continuous Cup Flight on 1-1/2" Core	9 Gauge Continuous Cup Flight on 2" Core
Drive Options	Gas engine, electric motor, PTO Double V-belts	Gas engine, electric motor, PTO Triple V-belts
Undercarriage	2-1/2" x 2-1/2" x 1/8" square structural tubing, 15" Wheels, Tapered Roller Bearings	3" x 3" x 1/8" square structural tubing, 15" Wheels, Tapered Roller Bearings
Motor Mount	Self-leveling with built in tension release	Self-leveling with built in tension release
Power Required	20 HP gas, 10 HP electric	35 HP gas, 20 HP electric
Capacity	2400-3000 Bushels/hr (1.4 MT/min)	4500-6000 BPH (2.7 MT/min)
Tires	ST225/75R15 c/w 4 Bolt Rim	

Table 6 - TL Auger Details

	TL10 SERIES	TL12 SERIES
Auger Tube	10" OD x 14 Gauge	12" OD x 12 Gauge
Auger Flight	9 Gauge Continuous Cup Flight on 2" Core	7 Gauge Continuous Cup Flight on 2-1/2" Core
Drive Options	Gas engine, electric motor, PTO Double V-belts	Gas engine, electric motor, PTO Triple V-belts
Undercarriage	2-1/2" x 2-1/2" x 1/8" Square Structural Tubing, 15" Wheels, Tapered Roller Bearings	3" x 3" x 1/8" Square Structural Tubing, 15" Wheels, Tapered roller bearings
Motor Mount	Self-leveling with built in tension release	Self-leveling with built in tension release
Power Required	27-30 HP gas, 20 HP electric	40-45 HP gas, 20 HP electric
Capacity	4500-6000 Bushels/hr (2.7 MT/min)	8000-10000 BPH (4.5 MT/min)
Tires	ST225/75R15 c/w 4 Bolt Rim	

Table 7 - HD Auger Specifications

		HD8-33		HD8-39		HD8 / HD10-46		HD8 / HD10-53		HD8 / HD10-59		66	
Tube Length		32' 10"   10.0m	39' 4"   12.0m	45' 11"   14.0m	52' 6"   16.0m	59' 1"   18.0m	65' 7"   20.0m						
A	Raised	19' 11"   6.07m	23' 7"   7.19m	27' 7"   8.41m	31' 6"   9.6m	33' 6"   10.21m	39' 7"   12.07m						
	Lowered	8' 7"   2.62m	8' 5"   2.57m	9' 9"   2.97m	11' 3"   3.43m	12' 8"   3.86m	14' 0"   4.27m						
B	Raised	11' 1"   3.38m	13' 1"   3.99m	15' 5"   4.7m	18' 0"   5.49m	20' 4"   6.2m	22' 8"   6.91m						
	Lowered	7' 0"   2.13m	7' 2"   2.18m	8' 6"   2.59m	9' 2"   2.79m	10' 9"   3.28m	12' 0"   3.66m						
C	Raised	14' 7"   4.45m	19' 3"   5.87m	20' 9"   6.32m	23' 8"   7.21m	26' 9"   8.15m	30' 1"   9.17m						
	Lowered	19' 0"   5.79m	21' 8"   6.6m	25' 11"   7.9m	29' 7"   9.02m	33' 9"   10.29m	37' 11"   11.56m						
D	Raised	11' 9"   3.58m	13' 5"   4.09m	15' 1"   4.6m	18' 1"   5.51m	19' 9"   6.02m	21' 9"   6.63m						
	Lowered	13' 1"   3.99m	15' 0"   4.57m	18' 7"   5.66m	21' 5"   6.53m	23' 7"   7.19m	26' 0"   7.92m						
E		10' 6"   3.2m	12' 6"   3.81m	14' 9"   4.5m	16' 9"   5.11m	19' 0"   5.79m	21' 4"   6.5m						
		21' 6"   6.55m	25' 3"   7.7m	29' 6"   8.99m	32' 1"   9.78m	38' 3"   11.66m	42' 8"   13.0m						
G	Raised	4' 10"   1.47m	7' 0"   2.13m	10' 10"   3.29m	11' 10"   3.61m	15' 4"   4.68m	n/a						
	Lowered	9' 2"   2.78m	11' 3"   3.42m	14' 9"   4.50m	15' 4"   4.67m	19' 8"   5.99m	n/a						
Transport Height		HD8-33: 12' 2"   3.71m	HD8-39: 11' 2"   3.41m	HD8-46: 12' 1"   3.68m HD10-46: 13' 9"   4.20m	HD8-53: 13' 6"   4.12m HD10-53: 14' 5"   4.40m	HD8-59: 13' 5"   4.09m HD10-59: 15' 3"   4.65m	n/a						
Transport Length		HD8-33: 31' 10"   9.71m	HD8-39: 38' 8"   11.80m	HD8-46: 45' 7"   13.89m HD10-46: 45' 10"   13.96m	HD8-53: 52' 0"   15.84m HD10-53: 52' 5"   15.98m	HD8-59: 58' 9"   17.89m HD10-59: 59' 0"   17.97m	n/a						
Transport Width		HD8-33/39/46: 9' 1"   2.77m HD10-46: 9' 1"   2.77m			HD8-53: 9' 8"   2.95m HD10-53: 9' 8"   2.95m	HD8-59: 11' 0"   3.35m HD10-59: 11' 0"   3.35m	n/a						
Auger Weight		HD8-33: 950lb   431kg	HD8-39: 1070lb   485kg	HD8-46: 1200lb   544kg HD10-46: 1536lb   697kg	HD8-53: 1360lb   617kg HD10-53: 1680lb   762kg	HD8-59: 1480lb   671kg HD10-59: 1860lb   844kg	HD10-66: 2010lb   912kg						
Hitch Weight		HD8-33/39: 200lb   91kg		HD8-46: 240lb   109kg HD10-46: 240lb   109kg	HD8-53: 240lb   109kg HD10-53: 280lb   127kg	HD8-59: 240lb   109kg HD10-59: 280lb   127kg	n/a						

Table 8 - TL Auger Specifications

		TL10-33	TL10-39	TL12-39
Tube Length		32' 10"   10.0m	39' 4"   12.0m	40' 0"   12.0m
A	Raised	19' 11"   6.07m	23' 7"   7.19m	22' 11"   6.99m
	Lowered	8' 7"   2.62m	8' 5"   2.57m	8' 11"   2.72m
B	Raised	11' 1"   3.38m	13' 1"   3.99m	13' 3"   4.04m
	Lowered	7' 0"   2.13m	7' 2"   2.18m	7' 8"   2.34m
C	Raised	14' 7"   4.45m	19' 3"   5.87m	17' 11"   5.46m
	Lowered	19' 0"   5.79m	21' 8"   6.6m	22' 4"   6.81m
D	Raised	11' 9"   3.58m	13' 5"   4.09m	13' 3"   4.04m
	Lowered	13' 1"   3.99m	15' 0"   4.57m	15' 1"   4.6m
E		10' 6"   3.2m	12' 6"   3.81m	12' 6"   3.81m
F		21' 6"   6.55m	25' 3"   7.7m	25' 3"   7.7m
G	Raised	5' 7"   1.70m	6' 9"   2.05m	5' 2"   1.57m
	Lowered	9' 8"   2.95m	11' 11"   3.38m	10' 4"   3.16m
Transport Height		11' 0"   3.34m	11' 4"   3.45m	13' 10"   4.22m
Transport Length		32' 11"   10.04m	38' 9"   11.82m	38' 2"   11.63m
Transport Width		9' 3"   2.82m		
Auger Weight		1060lb   481kg	1180lb   535kg	1740lb   789kg
Hitch Weight		n/a	220 lb   100kg	n/a

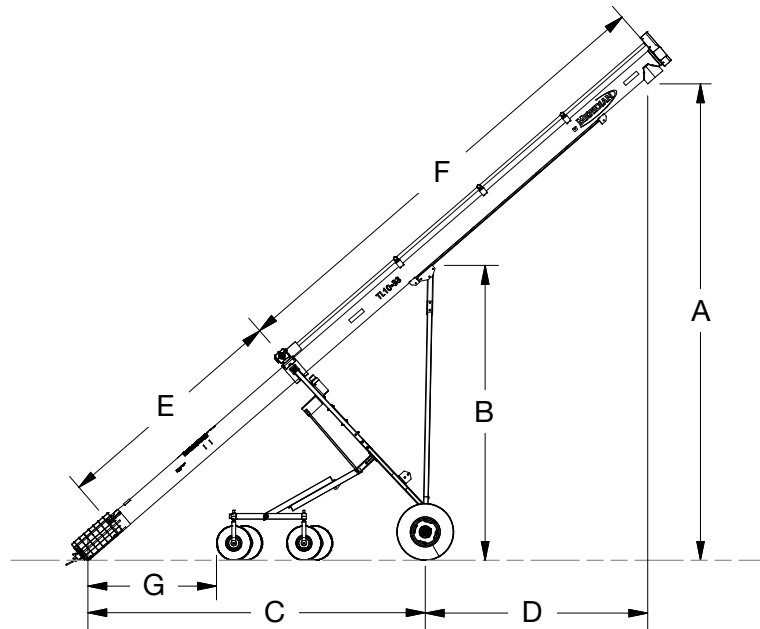

# LIMITED WARRANTY STATEMENT

1. Meridian Manufacturing Inc warrants each new Meridian Manufacturing Inc product (the "Goods") to be free from defects in material and workmanship under normal use and service for a period of two (2) years or ninety (90) days in the case of commercial use, from the shipment date from the Meridian dealer (FCA).
2. Meridian warrants replacement parts and components either manufactured or sold by, will be free from defects in materials or workmanship under normal use and service for thirty (30) days from the shipment date from the Meridian dealer (FCA), or the remainder of the original warranty period on the Goods, whichever is longer.
3. This warranty does not apply to:
  - a) To any merchandise or components thereof, which in the sole and unfettered opinion of Meridian, have been subject to misuse, unauthorized modifications, alteration, accident, negligence, product abuse or lack of required maintenance.
  - b) If repairs have been made with parts or by persons other than those parts or persons approved by Meridian.
  - c) To parts and accessories not manufactured by Meridian including, but not limited to, engines, batteries, tires, belts, PTO shafts or other trade accessories. Such parts shall be covered by the warranty given by the actual manufacturer, if any.
  - d) To failure of parts; or failure of parts to perform due to wear under normal or excessive service conditions; or to failure due to use by the Purchaser for purposes other than originally intended at time of manufacture, including without limitation using the Goods for mixing fertilizer, etc.; or used in excess of the built specifications.
  - e) To Goods used in areas exposed to corrosive or aggressive conditions including, but not limited to, salt water from either inside or outside the Goods.
  - f) To failures or defects arising out of damage during shipment or during storage.
  - g) To materials replaced or repaired under this warranty, except to the extent of the remainder of the applicable warranty.
4. The obligation of Meridian under this warranty shall not arise unless Meridian is notified and this warranty is presented together with a written statement specifying the claim or defect within thirty (30) days after the failure is first detected or made known to the Purchaser and within: (i) two (2) years, or ninety (90) days in the case of commercial use; or (ii) thirty (30) days in the case of replacement parts and components manufactured by Meridian; from the shipment date from the Meridian dealer (FCA). Meridian in its sole and unfettered discretion shall determine if the claim is valid and whether correction of the defect or failure shall be made by repair or replacement of the materials.
5. Title to any replaced materials Meridian wishes to have pass to it, shall pass to Meridian.
6. The obligation of Meridian hereunder extends only to the original Purchaser or Buyer to whom the Goods were initially sold. This warranty shall not be subject to any assignment or transfer without the written consent of Meridian.
7. The purchaser acknowledges that it has made its own independent decision to approve the use of the Goods and also the specific fabrication and construction procedures utilized to complete the Goods, and has satisfied itself as to the suitability of these products for its use.
8. This warranty is subject to the following limitations, provisions and conditions:
  - a) Meridian shall have no liability hereunder for any claims, including field re-work.

- b) Meridian shall not be liable for any incidental loss or damage, however caused, including, without limitation, normal wear and tear.
- c) Meridian makes no express or implied warranties of any nature whatsoever except for such express warranties as set out herein. The warranty provided herein is in lieu of and excludes all other warranties, guarantees or conditions pertaining to the Goods, written or oral, statutory, express or implied, (except the warranty as to title) including any warranty as to the merchantability or fitness for any particular purpose. Meridian expressly disclaims all other representations, conditions or warranties, expressed or implied, statutory or otherwise and any representations, warranties or conditions that may arise from a course of dealing or usage of trade. The warranty provided herein shall constitute Meridian's sole obligation and liability and the Purchaser's sole remedy for breach of warranty. No other warranty has been made by any employee, agent, or representative of Meridian and any statements contained in any other printed material of Meridian is expressly excluded herefrom. Meridian shall not be responsible for any warranty offered by the Purchaser to its customers with respect to the Goods and the Purchaser shall indemnify Meridian with respect to same if any of those customers makes a claim against Meridian relating to any such warranty.
- d) Subject to Meridian's obligations contained in paragraphs 1 and 2 herein, none of Meridian, its officers, directors, servants or agents shall be liable, or responsible for any loss or damage (including strict liability and liability for loss or damage due to items which the manufacturing processes are designed to identify) whether such loss or damage is caused by negligence in any manner whatsoever (including gross negligence, error, misrepresentation, misstatement, imprudence, lack of skill or lack of judgement).
9. The sole financial obligation of Meridian under this warranty shall be limited to the repair or replacement of the Goods as originally supplied and in no event shall they exceed the original cost of the Goods supplied.
10. Meridian shall not have any obligation under any warranty herein until all accounts have been paid in full by the Purchaser.
11. The construction and interpretation of this Warranty shall be governed by the laws of the Province of Saskatchewan.

Register your product at: [www.meridianmfg.com](http://www.meridianmfg.com)  
For warranty information send an email to: [warranty@meridianmfg.com](mailto:warranty@meridianmfg.com)

## **WARRANTY REQUEST PROCEDURE**

- The product must be registered with Meridian Manufacturing Inc.
- The purchaser must contact the dealer, from where the unit was purchased, immediately upon discovery of any defects.
- A completed Warranty Request (Claim) Form must be submitted by the dealer to Meridian's warranty representative for review and any subsequent course of action.
  - Warranty requests must be completed with ALL required information in order it to be considered for approval.
  - Send photographs of the entire piece of equipment, and of the specific area of concern.
- Warranty repair work will only be performed by Meridian or an approved representative of Meridian. Warranty work completed prior to Meridian's approval will NOT be honoured. Failure to follow this procedure may affect any or all of this warranty.
- All warranty requests will be adjudicated at the sole discretion of Meridian and in accordance with the terms and conditions of the warranty.



(833) 944-2345 | [www.meridianmfg.com](http://www.meridianmfg.com)